

Garrison Technical Manual

Vertical
Weatherboard

 **Garrison**[®]
by claymark



Ingrained Precision

in everything we do

claymark.co.nz

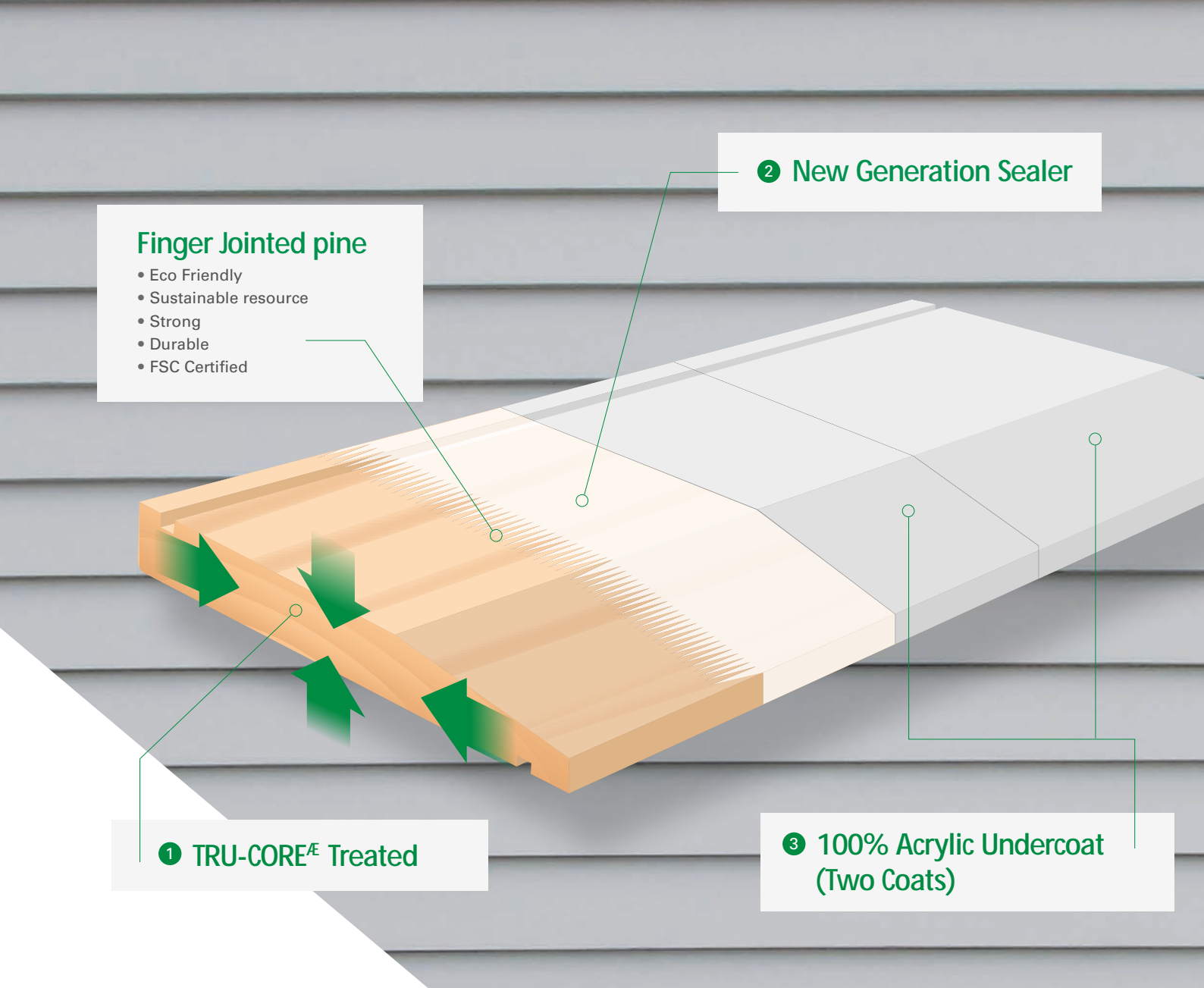

Finger Jointed pine

- Eco Friendly
- Sustainable resource
- Strong
- Durable
- FSC Certified

2 New Generation Sealer

1 TRU-CORE™ Treated

3 100% Acrylic Undercoat (Two Coats)

Contents

GARRISON COMPONENTS	2	Joining Garrison weatherboard	7
WEATHERBOARD INFORMATION	4	For laps and joints	7
INSTALLATION	5	Internal corners	7
Drained and ventilated cavities	6	Windows	7
Nailing guide	6	Cutting and sealing	7
Fixing cavity battens	6	Painting	8
Fixing Garrison weatherboard	6	Maintenance	9
Direct fixing	6	DRAWINGS DIRECTORY	10
Cavity fixing	6	CAD DRAWINGS – cavity fixed	11 - 25
Using non structural cavity batten	6	WARRANTY	26

New Zealand's most advanced weatherboard system.

Experience Claymark's Triple Protected Treatment. Unlike anything else in the market, three barriers of protection ensures your Garrison weatherboard lasts a lifetime*

1 Tru-core^{AE} Treated

- Unique carrier system penetrates microscopic channels in resins and glues
- 100% penetration of the Sapwood and Heartwood
- No damage to the wood structure
- No volatile organic solvents or harmful chemicals!
- 3 EPA registered and globally recognized fungicides
- 2 EPA registered and globally recognized termiticides
- 5 decay and termite actives

*In accordance with manufacturers warranty statement

2 New Generation Sealer

- Resists water uptake
- Resists resin/tannin bleed
- 100% Solids eco friendly technology
- UV cured seal coat

3 100% Acrylic Undercoat (Two Coats)

- Garrison primer system utilizes new generation Acrylic technology
- Waterborne technology
- 100% Acrylic composition
- Provides better adhesion, flexibility and weathering
- All 4 sides are evenly coated

Scope

Garrison® Vertical Weatherboards are for use as a direct fixed external wall cladding for buildings within the following scope:

- the scope limitations of NZBC Acceptable Solution E2/AS1, Paragraph 1.1; and,
- constructed with timber framing complying with the NZBC; and,
- with a risk score of 0-6 calculated in accordance with NZBC Acceptable Solution E2/AS1, Table 2; and
- situated in NZS 3604 Wind Zones up to, and including, Very High.

Garrison® Vertical Weatherboards are for use as a cavity fixed external wall cladding for buildings within the following scope:

- the scope limitations of NZBC Acceptable Solution E2/AS1, Paragraph 1.1; and,
- constructed with timber framing complying with the NZBC; and,
- with a risk score of 0-20, calculated in accordance with NZBC Acceptable Solution E2/AS1, Table 2; and,
- situated in NZS 3604 Wind Zones up to, and including, Extra High.

Weatherboard Information



Over the course of the last century weatherboard has endured itself as New Zealand's No. 1 home cladding of choice. Perfectly suited for New Zealand's changeable weather conditions and a superior choice for environmentally conscious Kiwis, coming from renewable managed resources.

Next Generation Weatherboard

Garrison is the next generation of treated finger-jointed pine, precision manufactured from Claymark's premium radiata pine blocks. A next generation patented treatment, Tru-Core®, is used to preserve and extend the life of the wood. This waterbased, eco-friendly treatment penetrates right to the core and has a proven history of performance. This gives state-of-the-art protection, resists tannin and resin bleed and provides better adhesion and flexibility, while being safer and more environmentally friendly than traditional oil- or solvent-based coatings. Claymark backs Garrison with a 15 year Written Limited Warranty.

Garrison is the first choice for any job that requires a superior finish. But it has more than great looks in its favour. It is an environmentally sound product, sustainably grown and precision manufactured in New Zealand to Claymark's exacting standards.

Garrison Information

Garrison Weatherboard features:

- Perfect finish
- 100% acrylic coating for better adhesion, flexibility and to prevent tannin and resin bleed
- Primed weatherboard boron treated & factory primed, treated using the Tru-Core process to H3.1 standard
- Deep Tru-Core protection means no re-treatment required for any field cutting, drilling or nailing.
- Tru-Core meets and exceeds New Zealand Standard 3640:2003
- Garrison is manufactured from premium radiata finger-jointed pine
- Garrison is cut to standard lengths of 6.1m
- Kiln dried target moisture content between 10 – 14%

Installation

Prior to cladding

Prior to the installation of Garrison weatherboards it is important to ensure that:

- The framing complies with the requirements of NZS 3604 timber framed buildings.
- The framing is straight and is within tolerances allowed by table 2.1 Tolerances of NZS 3604.
- Timber framing moisture content is less than 20%.
- Wall underlay is compliant with the requirements set out in table 23 of E2/AS1.

Garrison weatherboard sizes

Vertical weatherboard sizes

- 135x18mm
- 180x18mm

Care of product prior to installation

Correct handling and storage of Garrison weatherboards is critical for best performance, ease of use and warranty adherence.

Garrison weatherboards should be delivered when ready to be installed. Unnecessary storage time on

site can increase the risk of accidental damage and exposure to adverse conditions. All boards should be inspected upon delivery and any damage reported to your supplier. All Garrison should be lifted off the truck by hoist or hand. They should never be tipped from the truck.

While storing Garrison it is important to keep it dry and off the ground by at least 150mm. If you are storing outside always use a waterproof cover as a secondary to the Claymark wrap, but always ensure that there is sufficient air flow to avoid condensation.

Also avoid storing over puddles, other standing water or vegetation.

Deliveries should be timed to allow minimum time sitting on site, especially when weatherboards are in unfinished damp buildings or in an uncovered building allowing the chance of moisture uptake.

Where possible always store weatherboards in a covered building.

All Garrison weatherboards must be stored on a flat, level and firm platform.

Note: All warranty will be void if the product has not been kept dry before installation, or that has not been painted according to the specifications outlined above.



Drained and ventilated cavities

A drained and vented cavity is required behind Garrison Vertical weatherboards when the weather tightness risk score exceeds 6. For further information refer to Acceptable solution E2/AS1.

Nailing Guide

Fixing cavity battens

Structural Battens

The use of approved structural cavity battens allows Garrison weatherboards to be fixed directly to the cavity batten eliminating the need for larger fixings (refer table 1 below).

Structural cavity battens should be nailed over framing members and wall underlay to studs using 60 x 2.8mm hot dipped galv or stainless steel ring shank or jolt head hand driven nails. For gun driven use 64 x 2.8mm hot dipped galv or 65 x 2.87mm stainless steel ring shank nails at 300mm alternating either side of the batten centre line.

Non Structural Battens

This batten is fixed by the Garrison fixing penetrating the wall framing. A temporary fixing can be used until Garrison is fixed to the framing.

Fixing Garrison Weatherboard

Direct fixing (Option 1)

For direct fixing of Garrison weatherboards consult E2/AS1. Including reference to table 21.

Cavity fixing

Using structural cavity batten (option 2)

When nailing to a cavity batten that is structurally fixed, fix Garrison weatherboards using 75 x 3.15mm hot dipped galvanised jolt head nails. Single fixing 10mm from the lap 35mm from weatherboard edge.

Note: When installing Garrison weatherboard over a vented cavity, should be constructed in conjunction with E2/AS1. A vented cavity must be used where the E2/AS1 risk exceeds 6.

Cavity fixing

Using non structural cavity batten

When nailing to a cavity batten that is not structurally fixed, fix weatherboards using 90 x 4.0mm jolt head nail (35mm penetration to stud) or 75 x 3.15mm annular grooved nail (25mm penetration to stud) Single fixing 35mm from edge of overlapping board.

All Garrison products are manufactured with an active treatment that is nonreactive to all nails and fastenings, however, when used in combination with stainless steel fastenings, the long term durability of a project can be greatly increased.

We recommend hand nailing, a nail gun may be used as long as it does not bruise/damage the weatherboard and that the correct nail size is adhered to as per our nailing guide. Claymark endorses the use of the Paslode® JoltFast weatherboard nailing system with the appropriate nailing specification.

- Pre drill all boards 50mm from the end.
- All nails should be punched 2mm below the top surface of the board.
- Cavity battens to be Claymark 45 x 18mm H3.1 treated castellated batten.
- Ensure nogs to wall are spaced at 480mm centres.
- Stud spacings to NZS 3604 by designer.
- Provide polypropylene tape over wall wrap at 300mm centres. Horizontal between cavity battens if battens are more than 450 centres.

There should be a minimum of a 50mm overlap below the bottom plate or bearer, as required by E2/AS1.

We recommend that you use a complete board with no cuts in above all windows when possible. To allow for normal seasonal movement, nailing should not restrict movement, and always avoid nailing through overlapping boards. Garrison should always be nailed over studs with a maximum centre of 600mm.

Nailing patterns should comply with E2/AS1, industry standards and best practice. The minimum lap for the weatherboards is 25mm, and weather-grooves should line up.

Note: It is recommended that type 304 stainless steel fixings and flashings are used in seaspray and geothermal zones, it is the building designers responsibility to ensure all specified fastenings, fixings and flashings comply with NZBC E2/AS1

Table 1.

Weatherboard Type	Framing Set-Out	Nails (Direct Fixing)	Nails (Cavity Fixing)	Nailing Requirements	Wind Zone	Wind Barrier
Vertical to stud or batten	Studs @ 600mm centres max. Nogs @ 480mm centres max.	(Option 1) 60 x 2.8 Jolt Head (JH), Hot Dipped (HD), Galv. Nails	(Option 2) above Jolt Head (JH), Hot Dipped (HD), Galv. Nails	Single nail 35mm from board edge.	Low, Medium & High, Very High & Extra High	Lightweight Building Paper Heavyweight Building Paper or Rigid Sheath



Joining Garrison Weatherboard

Garrison should be fixed in full wall lengths where possible. If joints are unavoidable joint over a stud or batten. Scarf joint at 45° and use one fixing through the overlapping board. Prime cut ends twice. Best practice is to cover with a flat soaker.

For laps and joints

- Vertical laps to be 25mm
- 2mm end gap between boards
- Ensure that joints are made over supports
- Always drill for nailing within 50mm of board end

Internal corners

Mitre or butt fit junctions, in accordance with Acceptable Solution E2/AS1.

Windows

All windows should be installed in accordance with Acceptable solution E2/AS1.

All window details may change at anytime, please ensure strict accordance with E2/AS1, ensure support bars are provided in accordance with WANZ WIS refer to www.wanz.org.nz

A 10 mm gap must be maintained between bottom of weatherboards and flashings. All exposed cut ends need to be top coated and sealed.

Cutting and Sealing

When you cut Garrison weatherboard you do not have to re-treat, but you must prime any cuts with 2 coats of 100% exterior premium undercoat. When using putties, mastics and sealants with Garrison, ensure they are compatible with acrylic based paints and for exterior application, if you are unsure, seek professional advice from the sealant manufacturer.

Ensure end cut top coating above head flashings and any exposed cuts.

— Painting

Weatherboards must be dry before painting (check with moisture meter).

Garrison is a pre-primed and undercoated weatherboard to ensure the optimum finish for your construction, follow the instructions below

- Check board moisture content using a correctly calibrated moisture meter or measure board dimensions. If the board has greater dimensions than that of the profile spec it is likely to have gained moisture. Board moisture content should be below 15%.
- If board moisture content is elevated do not paint. Let the board dry back to factory dimensions. Painting boards at elevated moisture content increases the risk of shrinkage lap marks occurring.
- Check all end grain and cuts have been primed and undercoated.
- Nail holes should be primed prior to filling. Priming nail holes reduces nail hole moisture uptake.

All painting and preparation should be carried out in accordance with the appropriate clauses in AS/NZS 2311 Guide to painting of Buildings.

If weatherboards have been exposed to weather for any length of time without two quality coats of top coat and or the primer adhesion looks unsound it is recommended to re-prime in accordance with AS/NZS 2311. Contact Claymark for additional assistance.

Weatherboards must be painted when the surface is dry, if the weatherboards have been wet or had moisture in them, they must be allowed to return to their original state with a moisture content of 12 – 15%. If weatherboards are painted at a higher moisture content you may see swelling between the finger joints.

To protect against dimensional change, applying the manufacturer's recommended painting specification will provide protection against moisture uptake. Garrison will restrict moisture uptake, however, should Garrison be exposed to moisture prior to final painting and this results in temporary dimensional swelling, it is essential the Garrison product be given time to dry out and return to its original dimensions before the final coats are applied.

Remove all dirt, chalk or other contaminants before painting. All nail holes should be filled with exterior grade wood filler, then spot primed, with two coats of premium top coat exterior paint.

For an optimum finish a light sand is recommended before applying final coats of paint. Garrison should be

painted as soon as possible after installation, and no more than 90 days after installation. Primers cannot withstand extended periods exposed to the weather.

Apply a minimum of two full coats of 100% acrylic premium quality exterior paint with Tannin Blocking Properties as per paint manufacturers label instruction. You must use a paint with a LRV (light reflectance value) of greater than 45%. A Matt finish or Low Sheen is recommended rather than gloss finish.

Total Garrison paint film build should exceed 130 microns of dry film build (paint supplier can check this).

Top coats can be applied using a brush, roller or spray units. Spray may be either conventional or airless sprays. Ensure full coverage to specified film build is achieved. Ensure that the final coating is evenly applied on all surfaces of the boards.

Wet brushes with water prior to use to avoid clogging. However, ensure that the minimum paint film build is being achieved. In the hotter summer months it is recommended to undertake painting on the shaded side of the house and not in direct sunshine.

Where the top coat is being applied with a roller use a roller with a medium nap. Finish with light parallel strokes with a brush.

Dark colours absorb heat from the sun and increase the risk of dimensional change to the boards and substrate degradation. To comply with the Claymark warranty conditions, select colours in a range of 45% light reflective value (LRV) or greater.

Do not use sealants or glues between the boards, particularly in the horizontal laps, as this may inhibit natural seasonal board movement

- Claymark recommends the use of Dulux Weathershield X10 for top coating.



Timber weatherboards should be cleaned on a regular basis and at least once a year, houses situated in a sea spray zone should be checked and could require washing twice to three times a year. Particular attention should be paid to soffits and overhangs. Allowing mould, fungi and marine salts to build up by not washing could have a detrimental effect on both the paint and the timber substrate.

When maintenance is required, use a premium primer and premium undercoats followed by the topcoat using the same paint as originally used. If small paint or substrate defects appear these should be repaired early to prevent further unnecessary degradation to the substrate.

As timber weatherboards are a natural product you could experience some movement, if this occurs you should make good the affected areas by priming and then re-applying with the original topcoat. Timber weather boards are designed to accommodate moisture, thermal and seismic movement in the board laps.

DO NOT use SEALANTS or GLUES between the boards, particularly in the horizontal lap, as this may inhibit the natural expansion and contraction of the cladding. The movement of a building and timber substrates will reduce overtime and settle at a normal equilibrium.

Different sides of the house could face different characteristics, with north facing sides requiring more maintenance. Refer paint manufacture for time frame of repainting of house.

Drawings Directory

Cavity fixed Vertical drawings	CAD
Figure 1.01 balustrade – internal wall	11
Figure 1.02 base of wall – concrete floor	11
Figure 1.03 base of wall – timber floor	12
Figure 1.04 aluminium window – head	12
Figure 1.05 aluminium window – jamb	13
Figure 1.06 aluminium window – sill	13
Figure 1.07 external corner – mitred	14
Figure 1.08 pipe penetration	14
Figure 1.09 within board joint	15
Figure 1.10 eaves – angled soffit	15
Figure 1.11 eaves – flat soffit	16
Figure 1.12 corner moulding – flashing	16
Figure 1.13 internal corner butt	17
Figure 1.14 meter box – jamb	17
Figure 1.15 mitre box – head	18
Figure 1.16 no eaves	18
Figure 1.17 external corner	19
Figure 1.18 door jamb	19
Figure 1.19 door head	20
Figure 1.20 external corner – boxed	20
Figure 1.21 external corner – lapped and notched	21
Figure 1.22 internal corner – internal moulding	21
Figure 1.23 internal corner – mitred	22
Figure 1.24 internal corner – w flashing	22
Figure 1.25 parapet capping	23
Figure 1.26 weatherboard fixing details	23

Figure 1.01 Cavity fixed – balustrade – internal wall

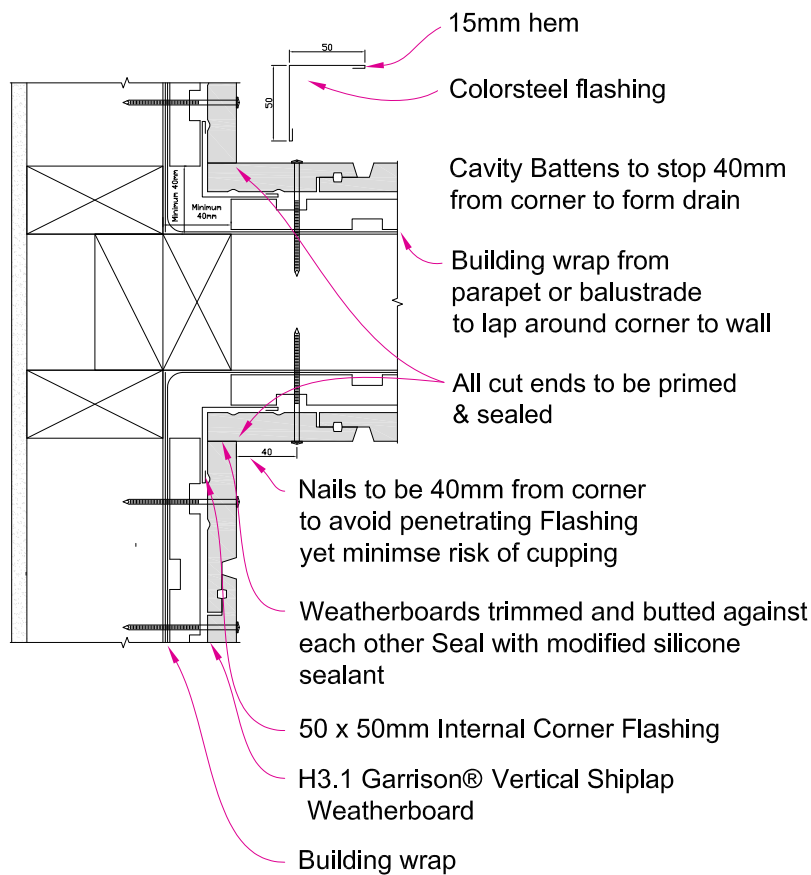

Figure 1.02 Cavity fixed – base of wall – concrete floor

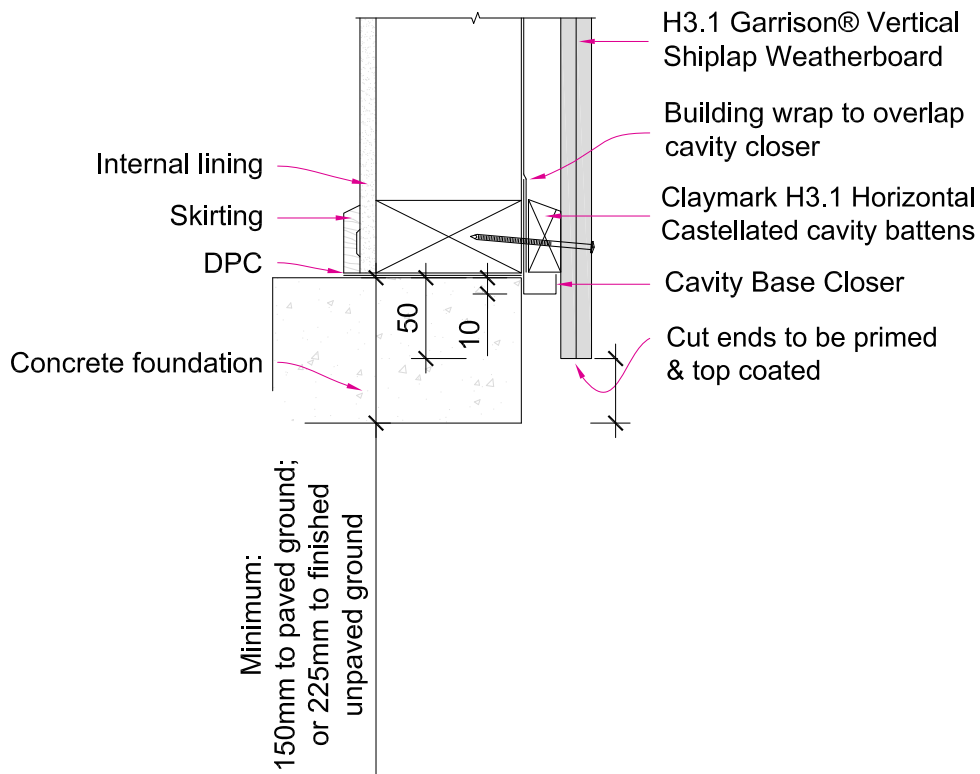

Figure 1.03 Cavity fixed – base of wall – timber floor

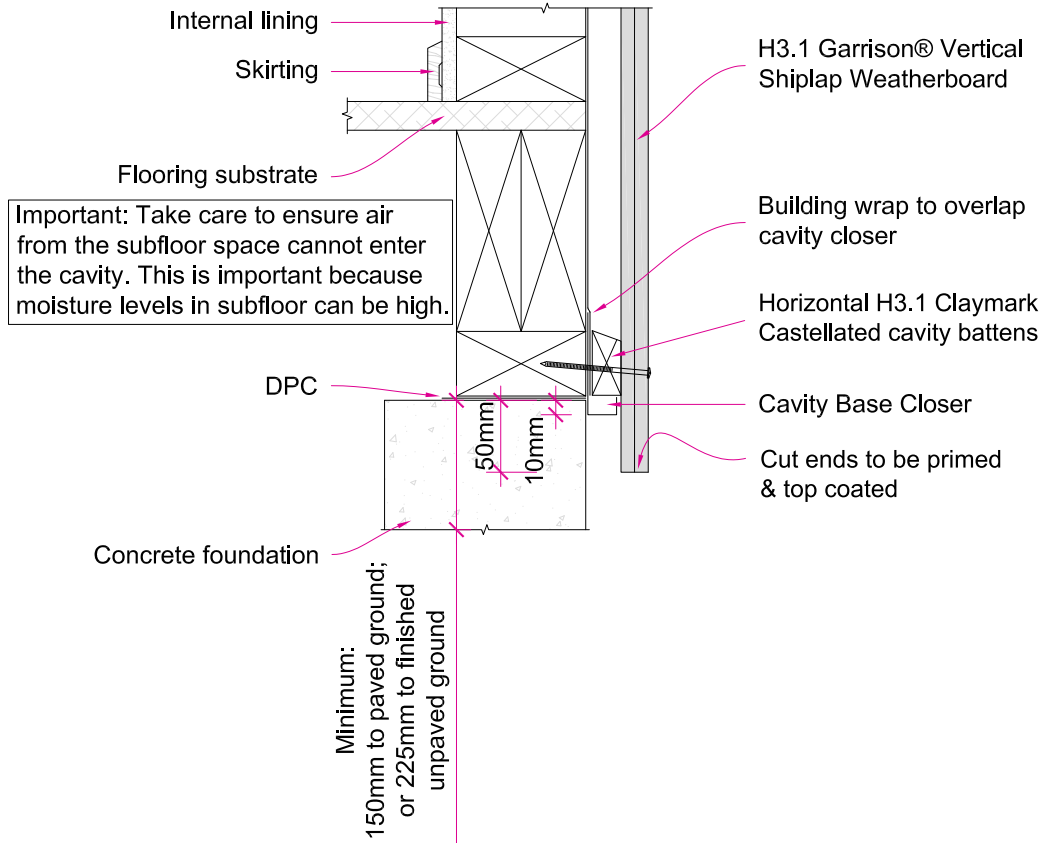

Figure 1.04 Cavity fixed – aluminium window – head

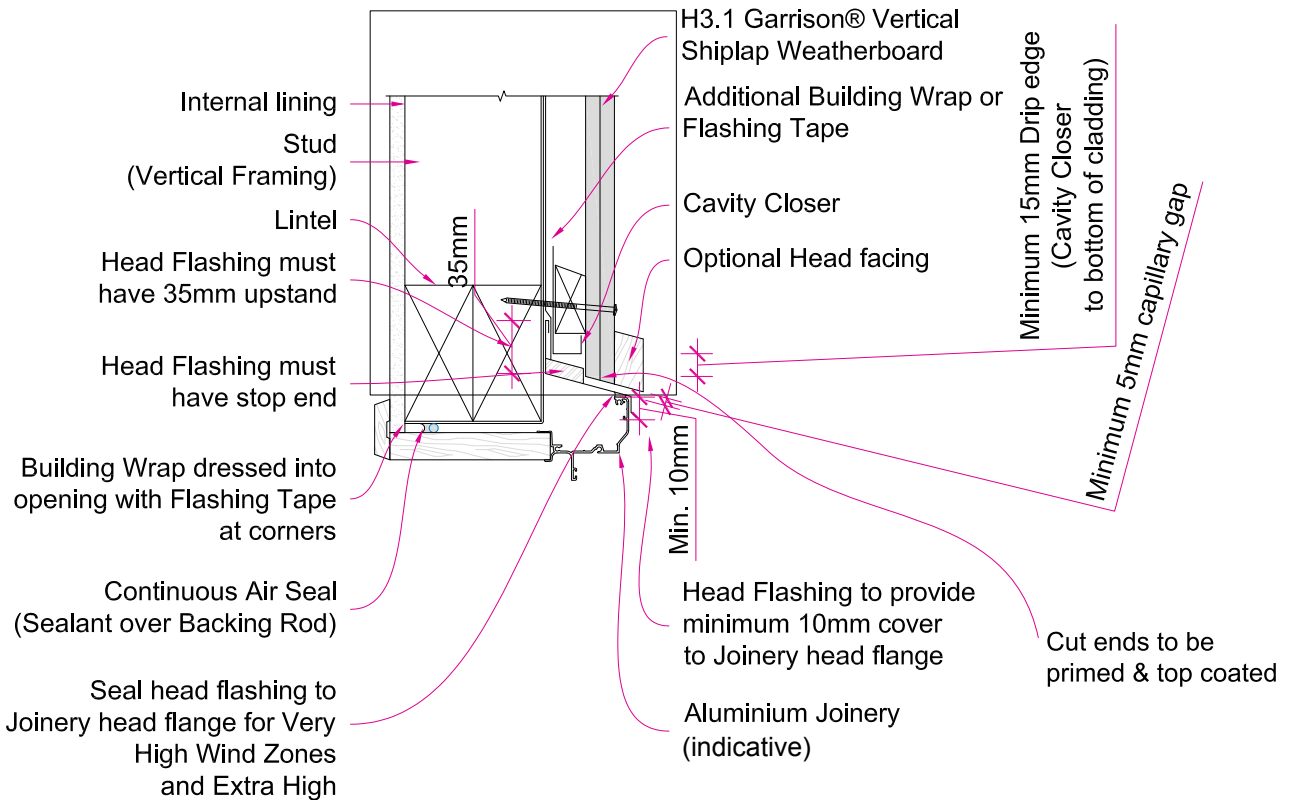

Figure 1.05 Cavity fixed – aluminium window – jamb

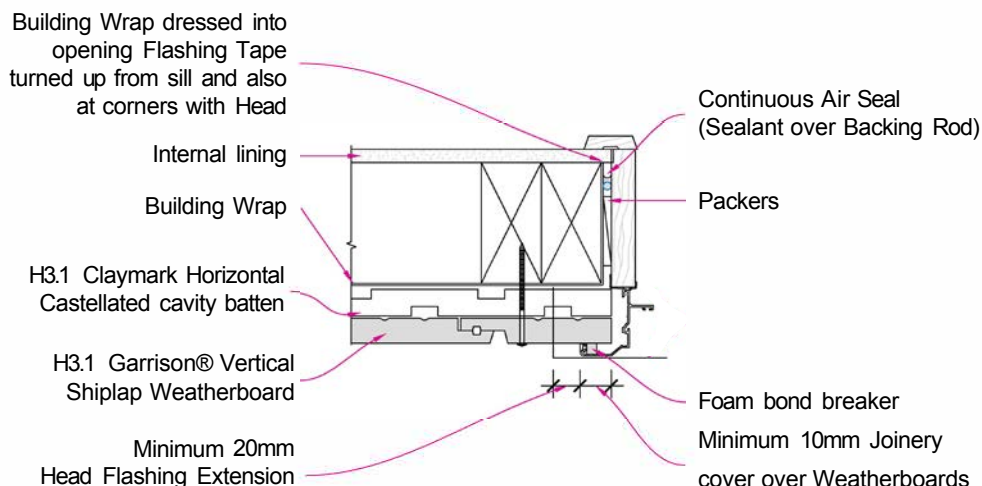

Figure 1.06 Cavity fixed – aluminium window – sill

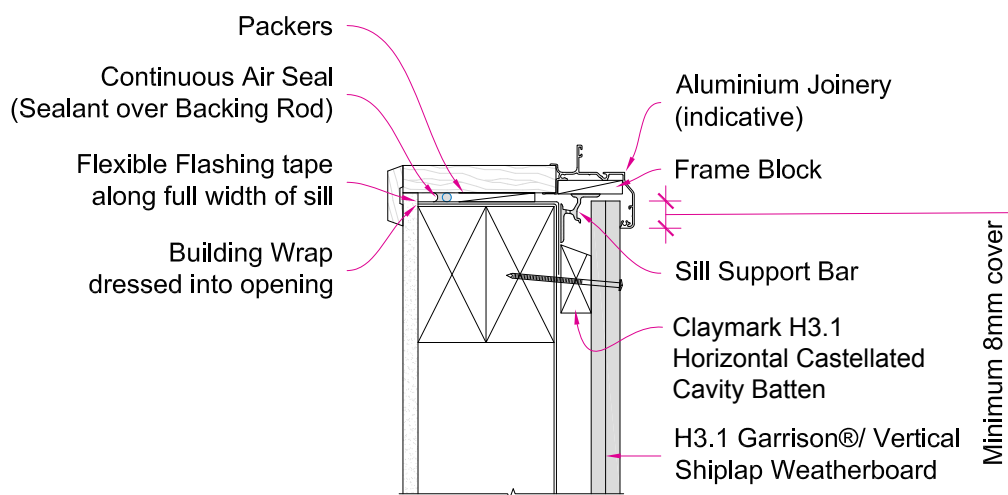

Figure 1.07 Cavity fixed – external corner – mitred

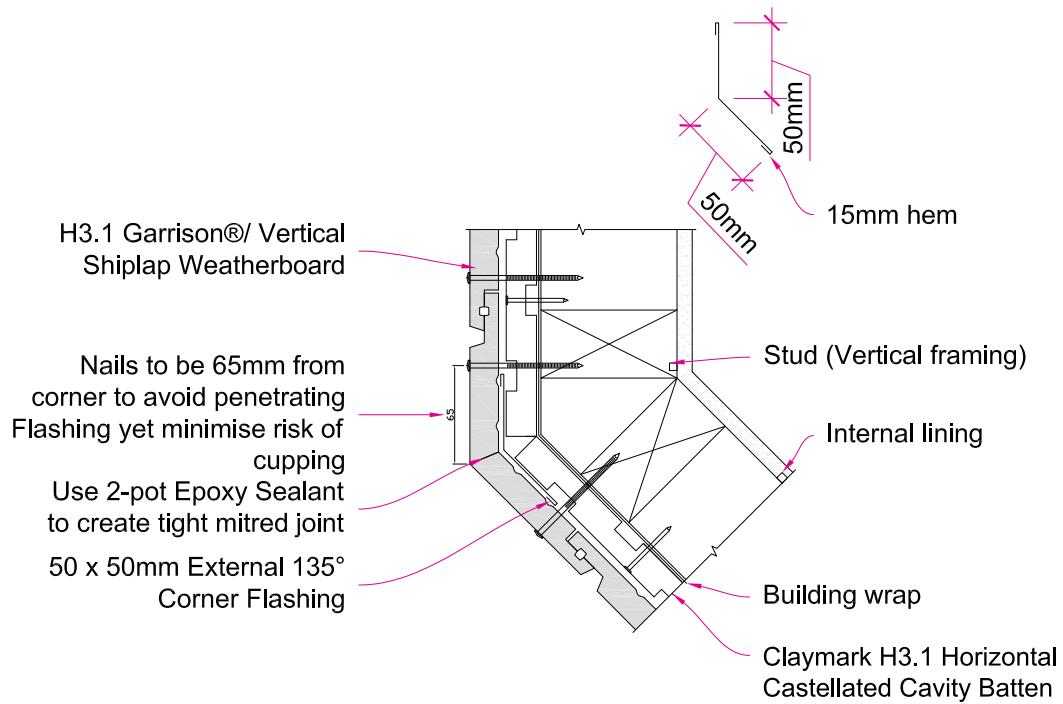

Figure 1.08 Cavity fixed – pipe penetration

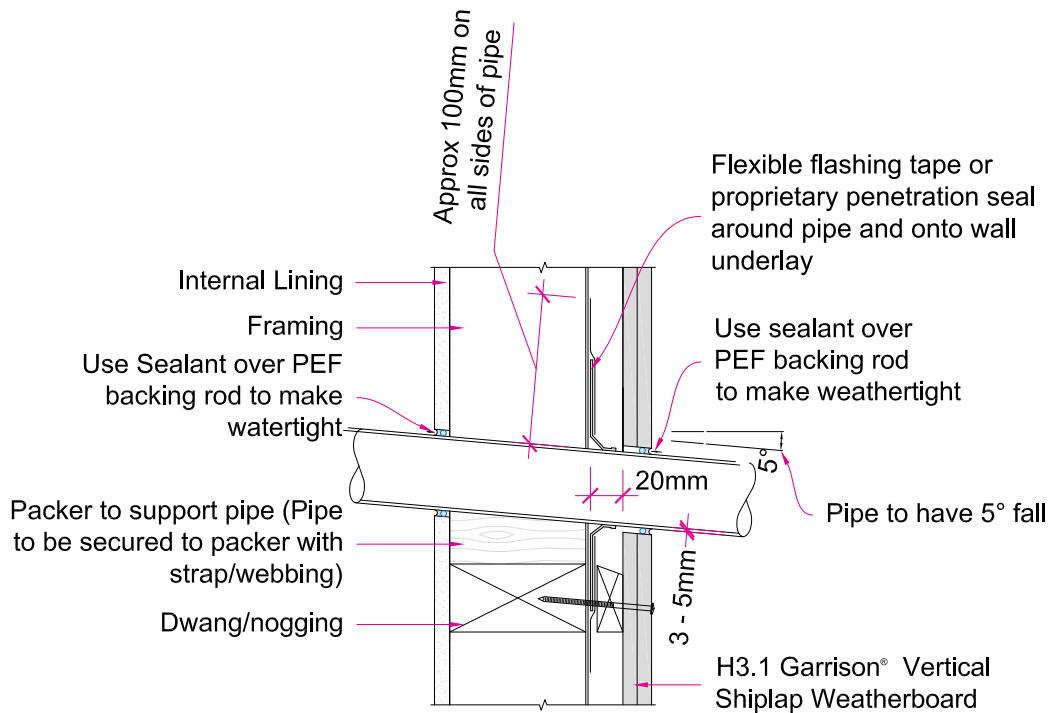

Figure 1.09 Cavity fixed – within board joint

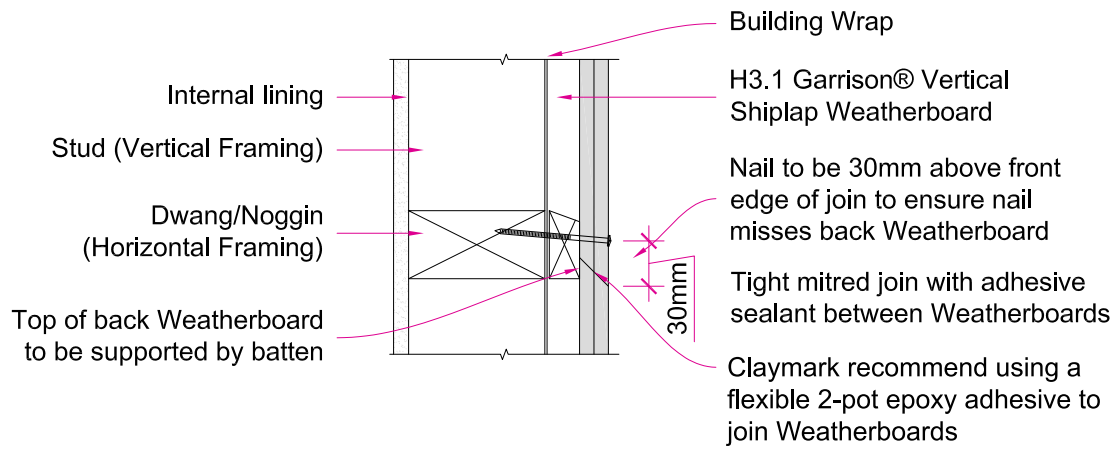

Figure 1.10 Cavity fixed – eaves – angled soffit

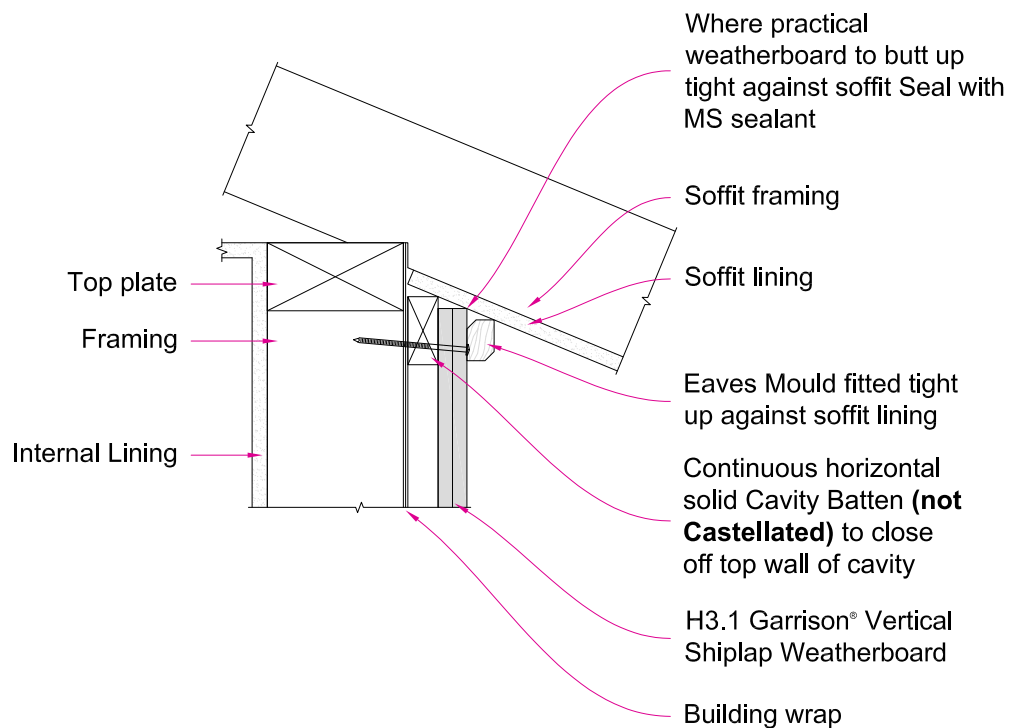

Figure 1.11 Cavity fixed – eaves – flat soffit

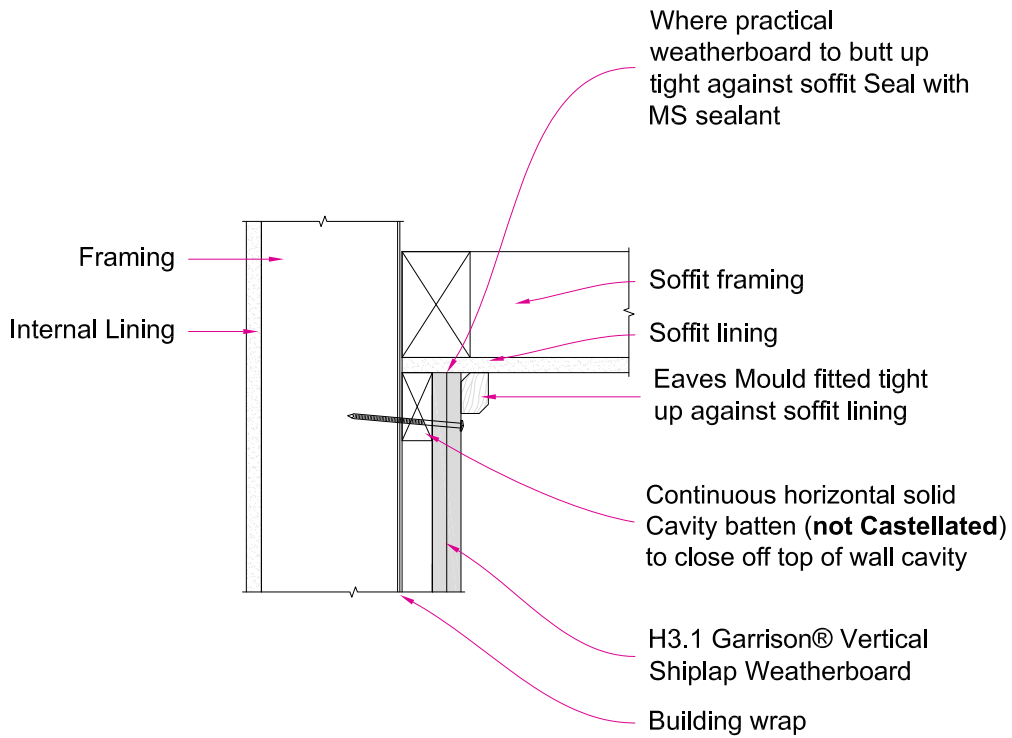

Figure 1.12 Cavity fixed – corner moulding – flashing

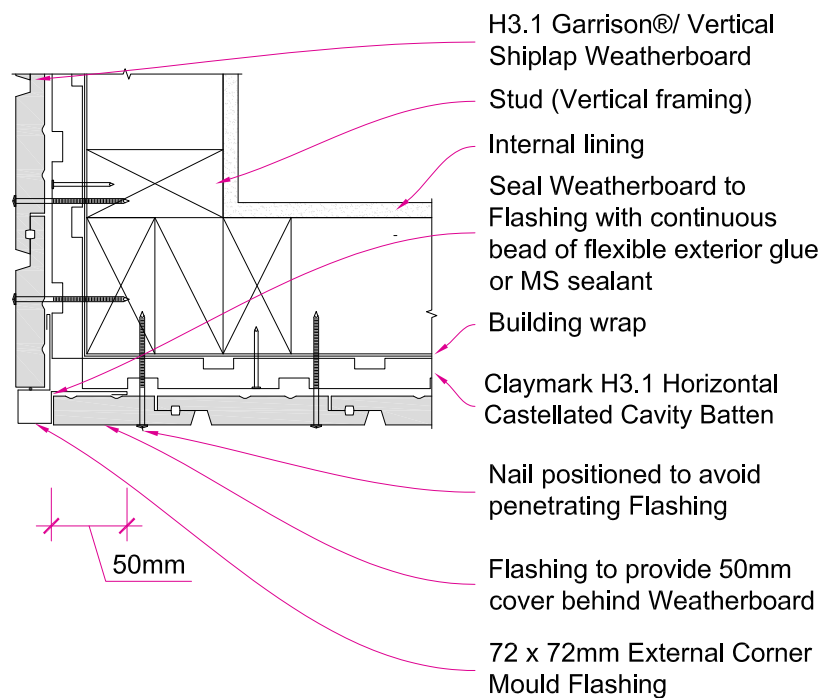

Figure 1.13 Cavity fixed – internal corner butt

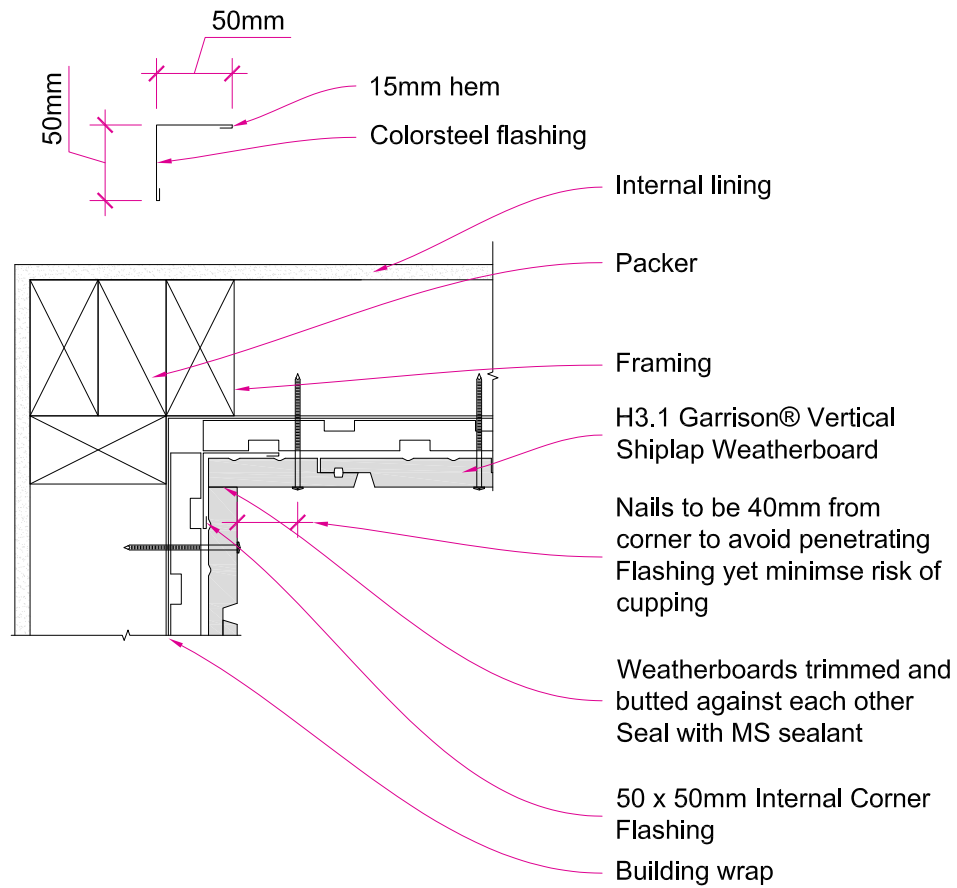

Figure 1.14 Cavity fixed – meter box – jamb

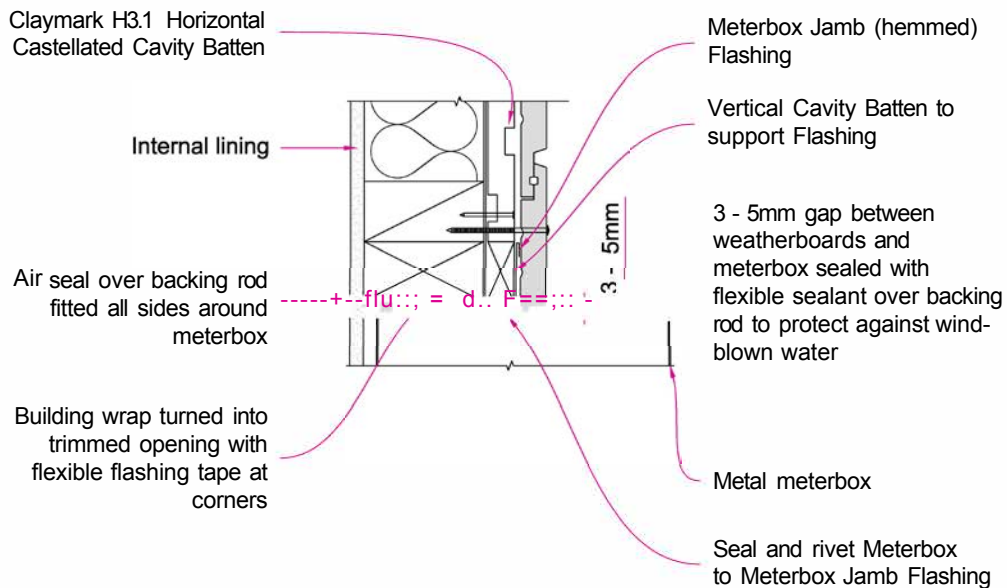

Figure 1.15 Cavity fixed – mitre box – head

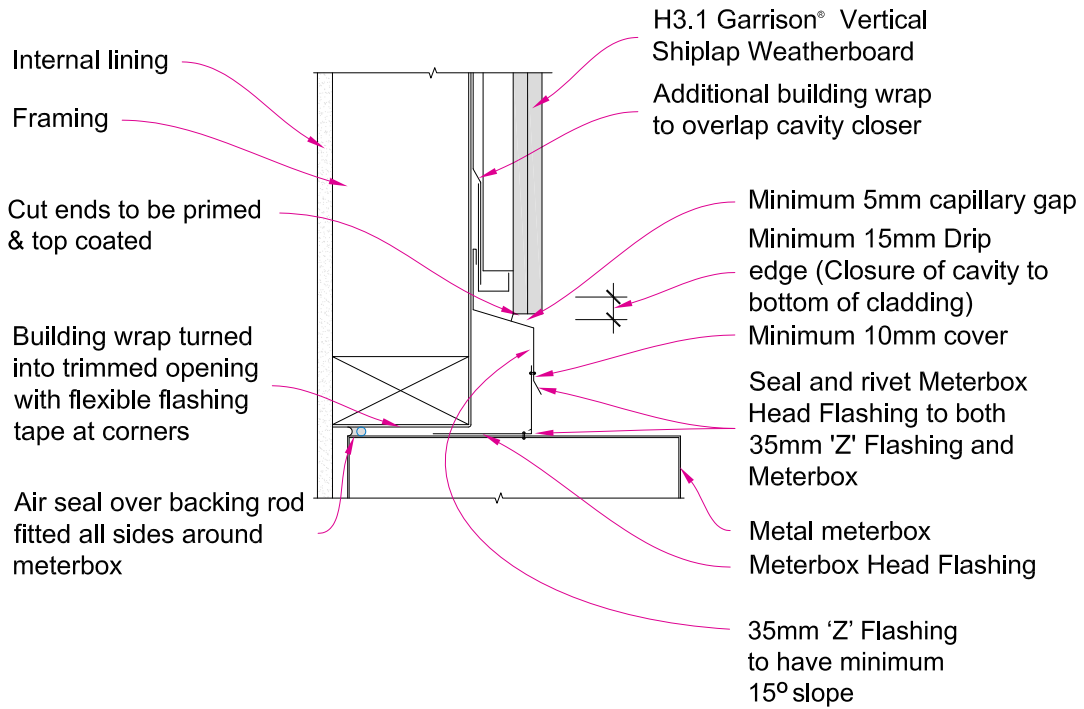

Figure 1.16 Cavity fixed – no eaves

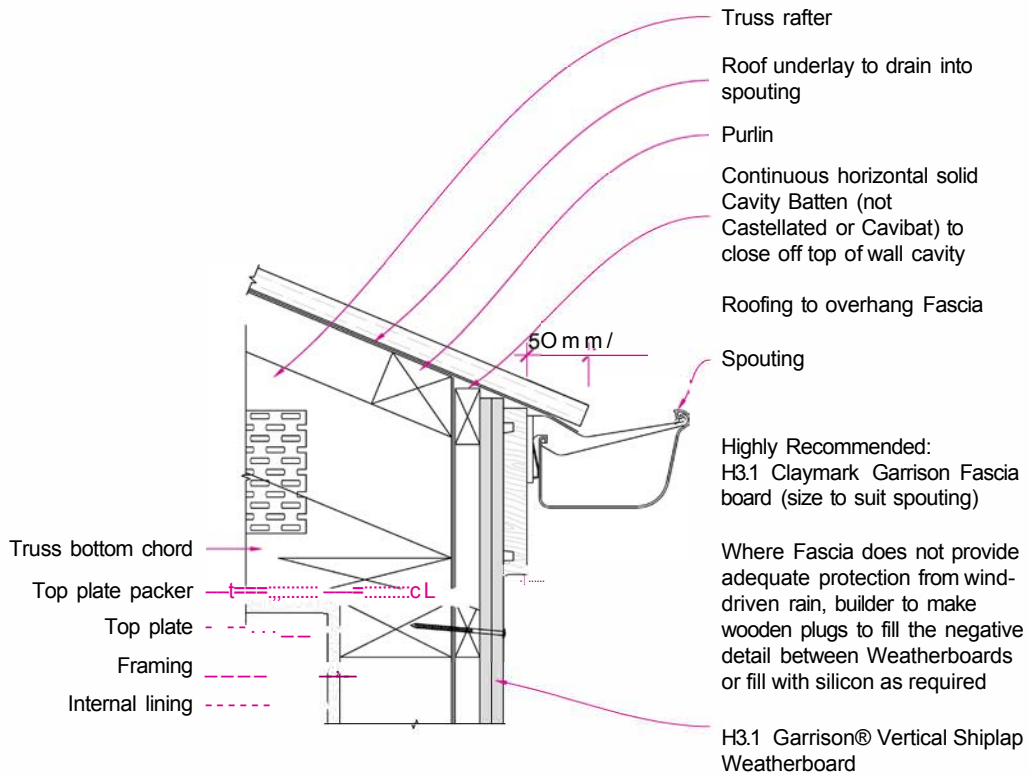

Figure 1.17 Cavity fixed – external corner

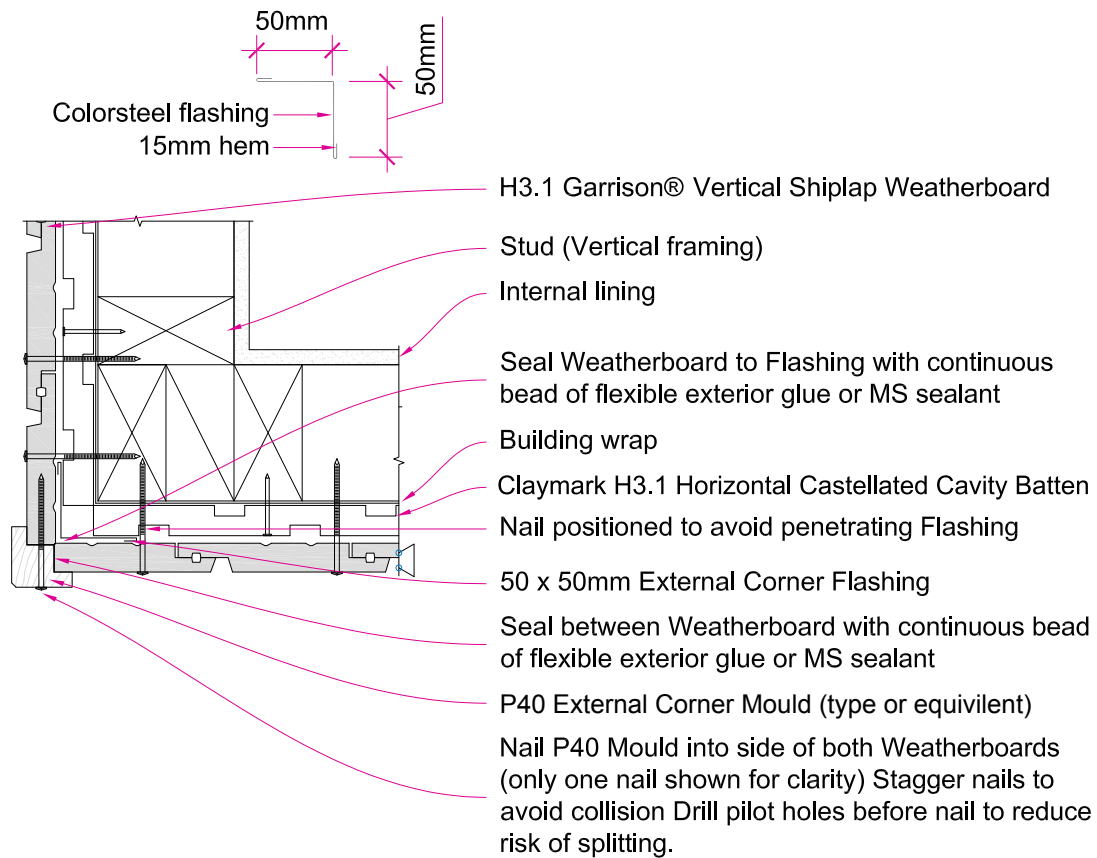

Figure 1.18 Cavity fixed – door jamb

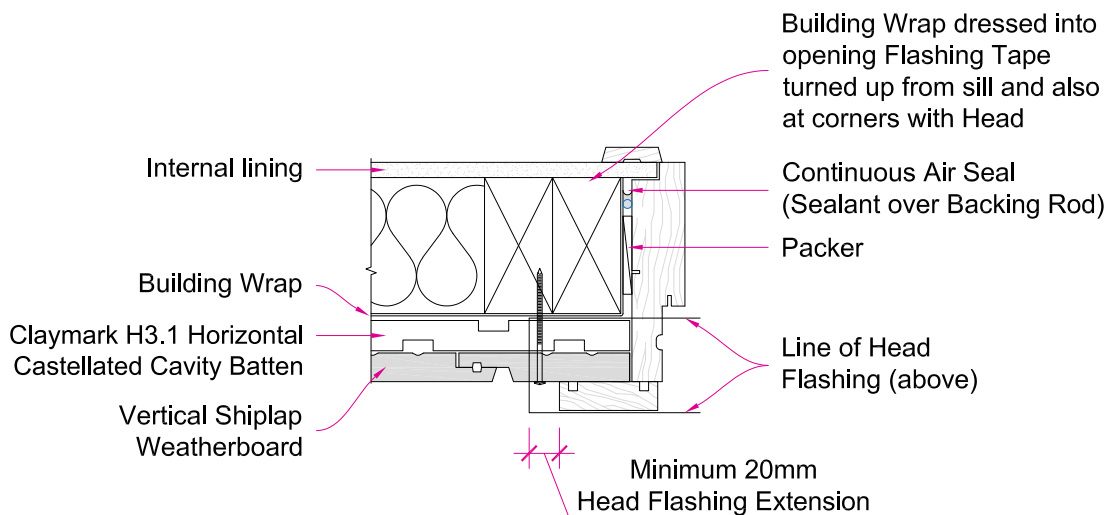
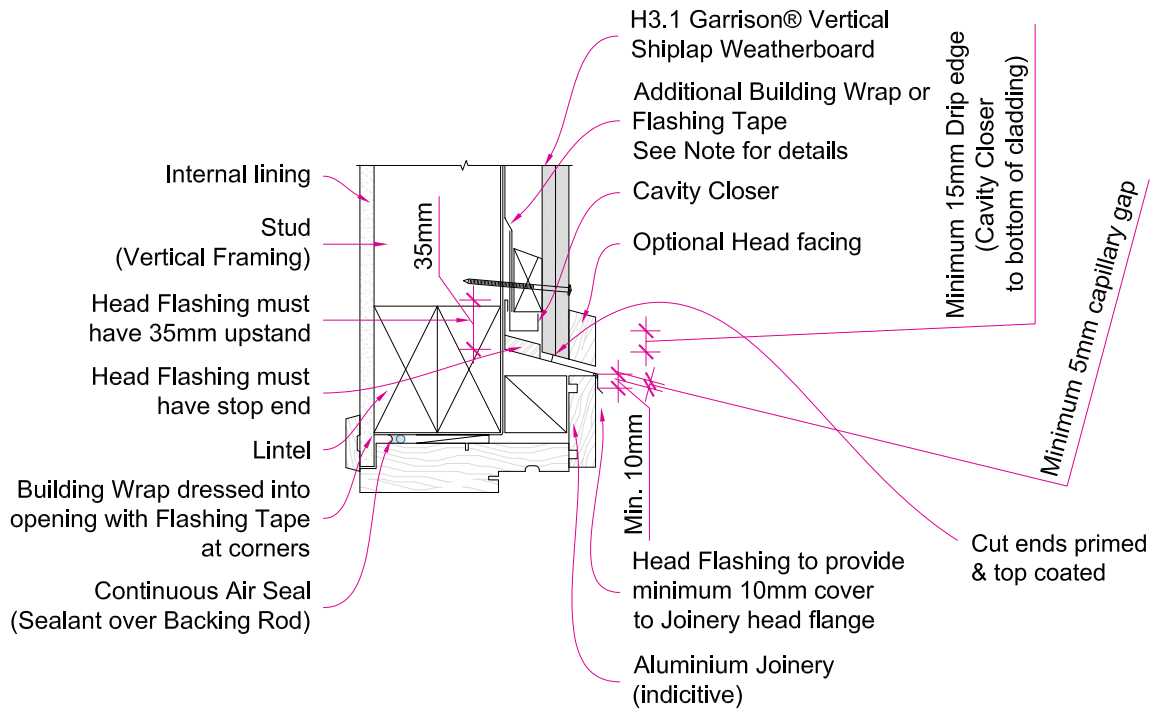

Figure 1.19 Cavity fixed – door head



Note: Additional Building Wrap to extend up wall to nearest lap above and extend down as far as possible into Cavity Closer.

Alternatively Flashing Tape to extend up wall a minimum of 50mm above Cavity Closer and extend down as far as possible into Cavity Closer.

Figure 1.20 Cavity fixed – external corner – boxed

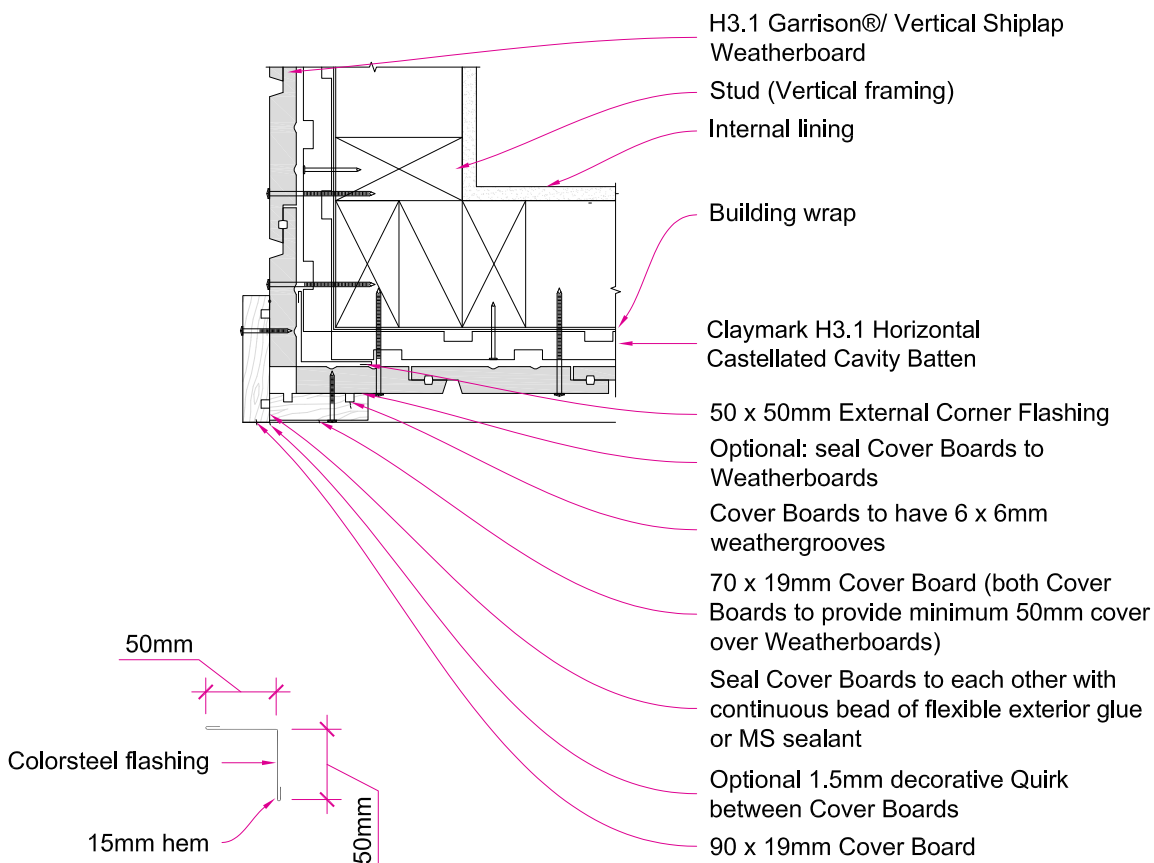

Figure 1.21 Cavity fixed – external corner – lapped and notched

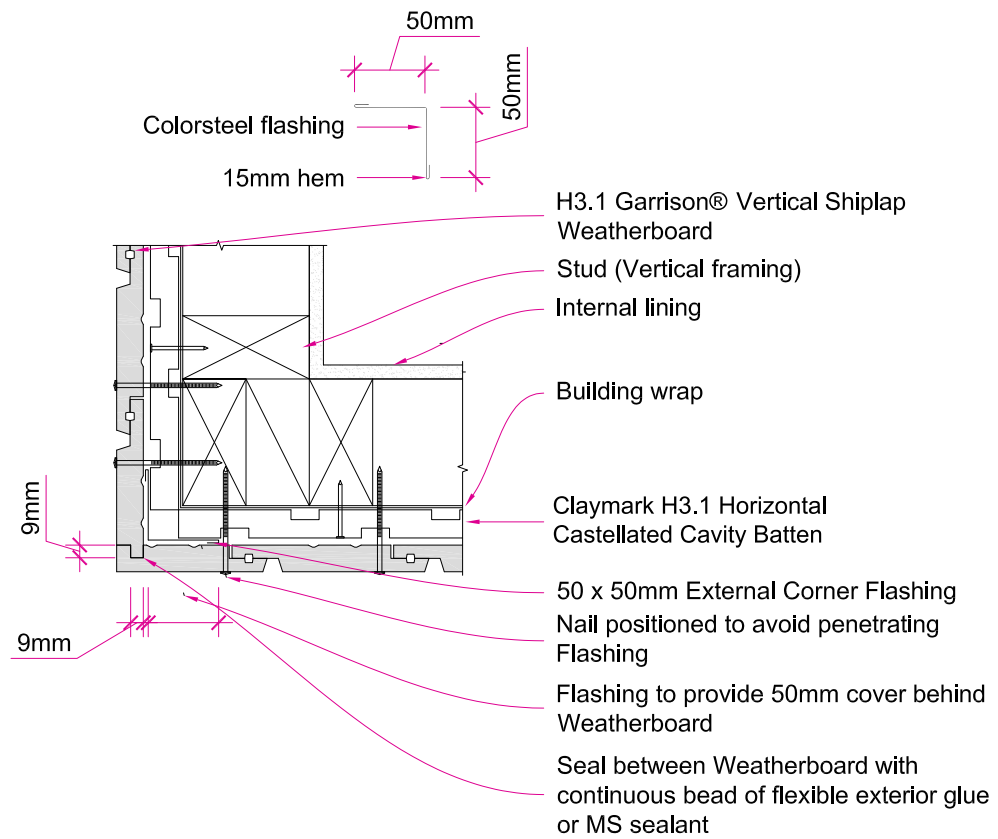

Figure 1.22 Cavity fixed – internal corner – internal moulding

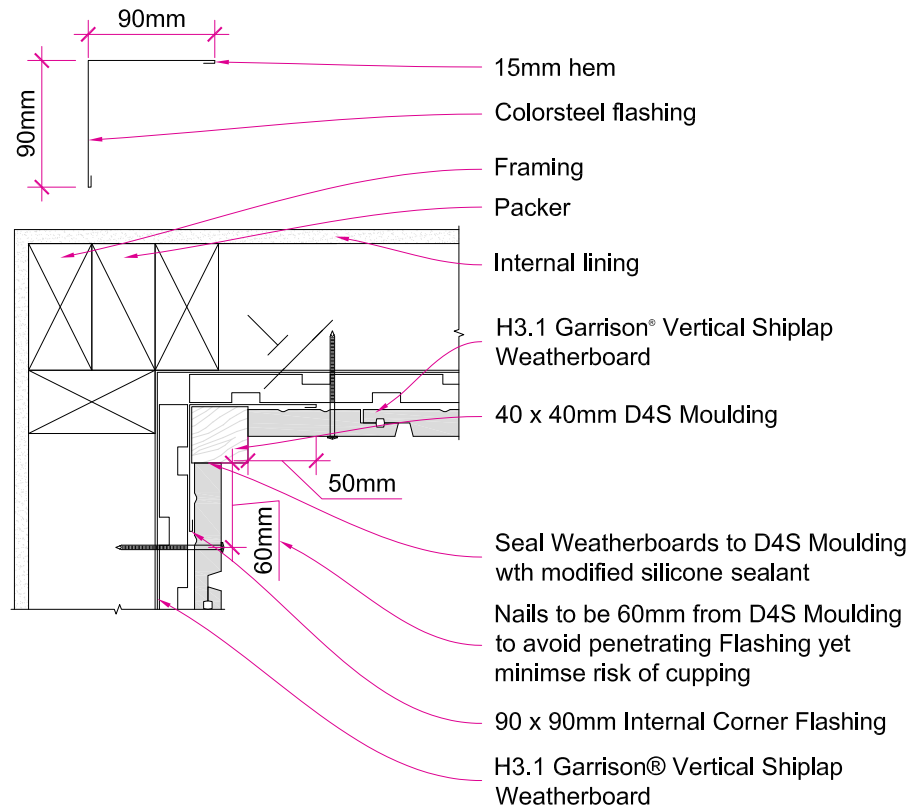

Figure 1.23 Cavity fixed – internal corner – mitred

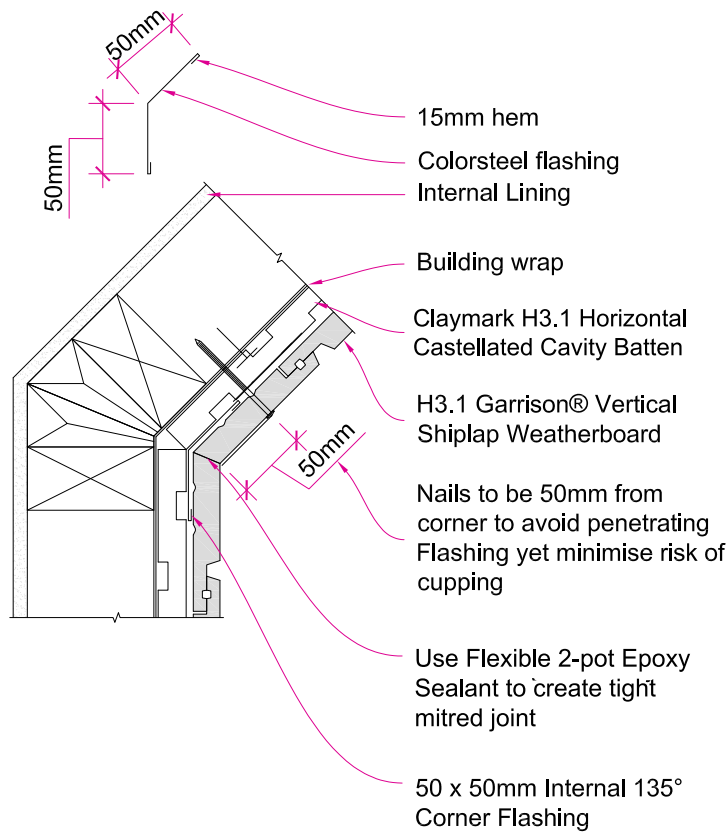

Figure 1.24 Cavity fixed – internal corner – w flashing

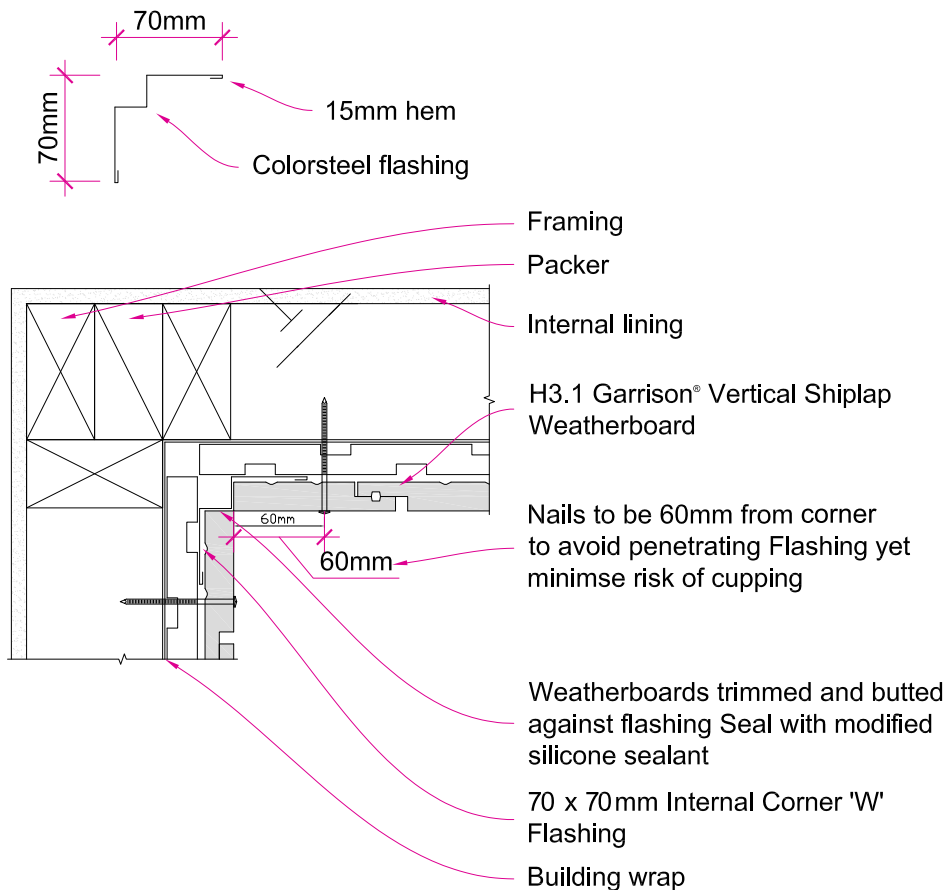

Figure 1.25 Cavity fixed – parapet capping

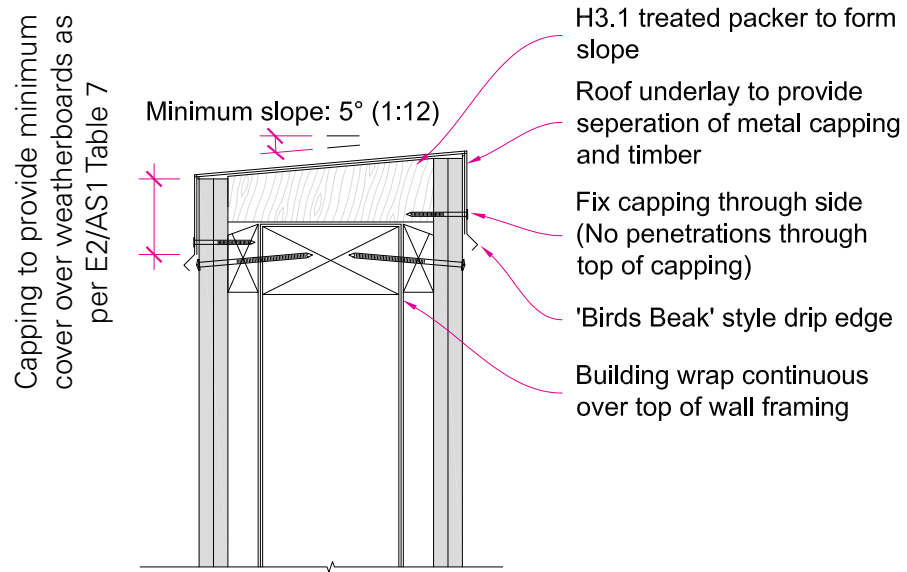
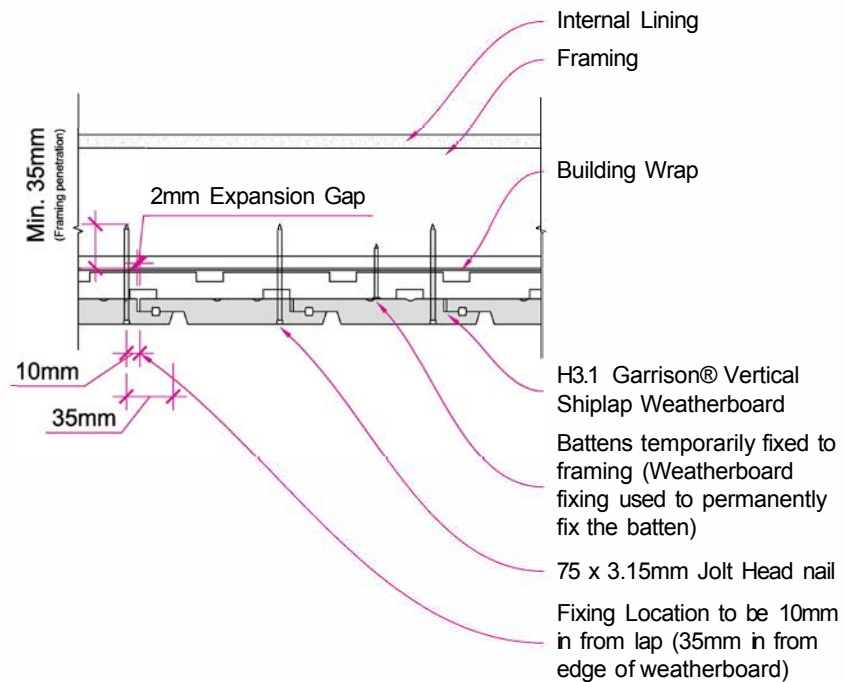

Figure 1.26 Cavity fixed – weatherboard fixing details



Note: Nails are to be on an upward angle to prevent water running down the nail through the cavity (nogs/dwangs at 400mm to 480mm centres)

— Warranty

Conditions of Warranty:

To validate the warranty all procedures and instructions must be strictly followed. All fixers of the product must be a licensed building practitioner.

Limited Warranty – Paint Pre-Finished Board Limited Warranty Two Years

Garrison is supplied with one coat of new generation sealer and two machine applied acrylic undercoats. Claymark offers a Limited Warranty for a period of two years from the date of installation or exposure of the board. This Limited Warranty applies when Garrison is finished with two coats of premium Acrylic topcoat within 90 days from installation. If for any reason any remedial work is required under this warranty which does require repainting certain areas, the customer must acknowledge and accept that there may be slight variations from the new paint being applied. Film Erosion: The paint film resists erosion leading to substrate exposure. Moisture: Provides protection to the substrate from external moisture. Mildew: The film provides mildew resistance.

Limited Warranty 15 Year Limited Warranty Against Insects and Decay

Garrison products are proudly backed by a limited 15 Year warranty against any fungal decay/rot and insect attack (termites). Where any Garrison product, installed in compliance with manufacturer's recommendations, becomes structurally unserviceable within 15 years of purchase, due to fungal decay/rot and insect attack (termites), replacement material will be provided by the manufacturer. This warranty is subject to terms and conditions in the handling guide, including adherence to building codes and standards. For any claim to be activated, Claymark must receive written notification within 30 days of the defect becoming apparent. For best performance and results, you must follow all of the recommendations as set out in the Garrison Handling Guide.



© Claymark Group Ltd Partnership. All rights reserved. All intellectual property and images included in this Technical Manual are the property of Claymark Group Ltd Partnership. No part of this document may be reproduced without the express (written) consent of Claymark Group Ltd Partnership. Claymark Group Ltd Partnership is not responsible for any errors and omissions in this document, nor for any specifications of work based upon this information.

J003934 13/06/2023 June V-70



Ingrained Precision

in everything we do

claymark.co.nz