

SP2x



**Micro Jig, Inc.**  
PO Box 195607  
Winter Springs, FL 32719, USA.

Tel: 1-407-696-6695  
Web site: www.microjig.com  
Email: sales@microjig.com

Copyright © 2009 Micro Jig, Inc.

# MJ Splitter Steel PRO System with Dedicated Automatic Kerf Keeper

## Installation Manual - SP-2x (V2.1) 0311

### Low Profile Multi Function Splitter with Stainless Steel Core

- **Micro Incremental Tension Adjustments** – Each additional “+” sign on the splitter surface means an additional +0.003” offset for precise amount of work piece control.
- **Mini Feather Board Effect Behind Saw Blade** - Keeps your stock pushed against the rip fence to minimize kickback.
- **Dual Splitter Functionality** – Control both sides of work piece simultaneously with selective mini feather board effects.
- **Automatic Kerf Keeper** – A dedicated device that engages automatically if the saw kerf begins to close under tension. Its function is to reduce tension on the MJ Splitter Steel PRO and the saw blade for safer operation.
- **Fully Customizable** – Install at specific blade heights to reduce the distance between the saw blade and the MJ Splitter Steel PRO.
- For installation on a Zero Clearance Insert (ZCI) without an existing splitter opening ONLY!
- For making 90° cuts ONLY – MJ Splitter Steel PRO System will NOT accommodate cuts with a tilted arbor!

**US Patent 7,475,621 - Made in USA**

### Package Contents -- If there are any damaged or missing parts, please contact Micro Jig, Inc. Do not contact your dealer.

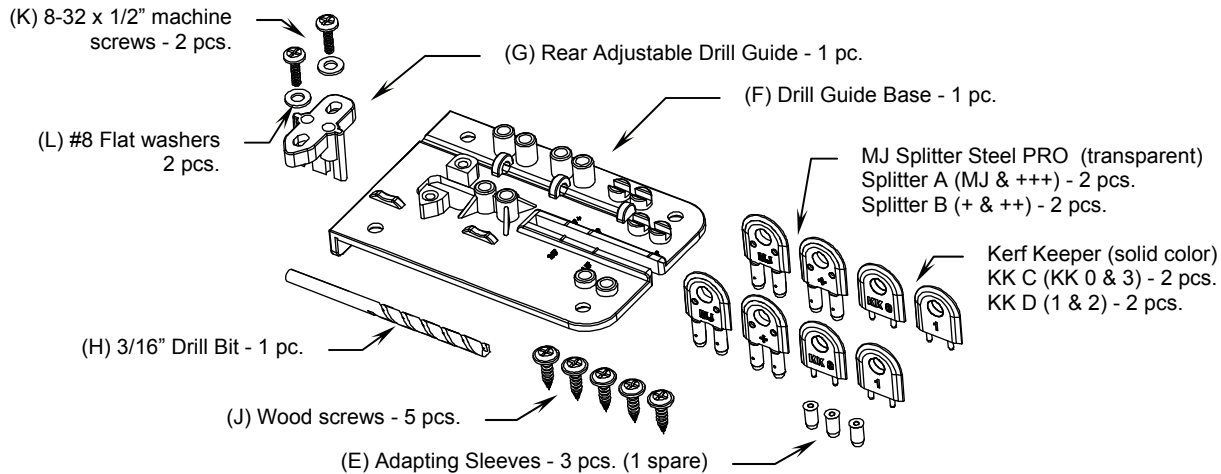

### Two PRO models are available.

Note: The MJ Splitter Steel PRO System is designed to work with a 10" saw blade only.

**Model # SP-2 PRO (Blue) - 1/8" Kerf**  
For Full 1/8" Kerf 10" Saw Blade  
Blue Splitter Thickness : 0.118" (±0.001")  
Kerf Range 0.118" - 0.145" (3.0 - 3.2mm)

**Model # SP-2TK PRO (Orange) - Thin Kerf**  
For 10" Thin Kerf Saw Blade  
Orange Splitter Thickness : 0.086" (±0.001")  
Kerf Range : 0.090" - 0.118" (2.29 - 3.0mm)

### IMPORTANT

- DO NOT USE 1/8" SPLITTER WITH THIN KERF BLADE OR VICE VERSA.
- THE SPLITTERS ARE NOT INTERCHANGEABLE BETWEEN MODELS.

The MJ Splitter Steel PRO System offers multiple installation options to accommodate different table saw cutting tasks. We recommend at least one **Double MJ Splitter Steel PRO** installation as shown in Drawing A for general cutting, and one **MJ Splitter Steel PRO/Kerf Keeper** Combination installation as shown in Drawing D for ripping solid wood. Every installation option must have its dedicated saw kerf created on a new ZCI. Two installations on the same ZCI are possible if it can be rotated 180° as in Drawing E.

<p><b>(A)</b> With a <b>Double MJ Splitter Steel PRO</b> installation, both sides of the work piece are kept away from the spinning saw blade upon exit. This set-up works best with dimensionally stable material, e.g., plywood, MDF, etc. A minimum space of 2" is required.</p>	<p><b>(B)</b> With a short throat plate opening where there is less than 2" of space with a fully raised 10" saw blade, a single MJ Splitter Steel PRO installation on the ZCI will provide a mini feather board effect against the fence. A minimum space of 1-1/4" is required.</p>	<p><b>(C)</b> An MJ Splitter Steel PRO and Kerf Keeper Combination installation is designed for solid wood ripping. This is a completely separate installation from the Double MJ PRO Splitter installation—the hole alignment is different.</p>	<p><b>(D)</b> When ripping a solid wood board under tension, Drawing D shows the Kerf Keeper being pulled out automatically by the closing saw kerf. The Kerf Keeper will travel with the pinched kerf and keep it open to reduce stress on the splitter and the saw blade. <b>Important:</b> The table saw must be turned off as soon as a closing saw kerf is observed.</p>	<p><b>(E) Optional Installations:</b> The Drill Guide also provides alignment marks for either a <b>Double MJ Splitter Steel PRO</b> or an MJ Splitter Steel PRO/Kerf Keeper Combination when installed closer to a 10" saw blade and/or at lower blade heights. Check the Drill Guide for available blade height installations. Drawing E shows one ZCI with two saw slots from different blade heights and splitter holes on a single ZCI.</p>

### PREPARATION For best results, we suggest that you read this Installation Manual thoroughly before you start!

- Rip fence must be parallel to the saw blade if the MJ Splitter Steel PRO System is used with the GRR-Ripper® System.
  - Zero Clearance Insert (ZCI) must be level with the table saw top.
  - To achieve a “feather board” effect, the ZCI must fit snugly in the opening and **ALL** installation steps must be closely observed.
  - A kerf in the ZCI must be created at 90° with a 10" saw blade (without stiffener) raised to the selected blade height according to the alignment marks on the Drill Guide. For illustration in this manual, the **highest blade height** setting for the maximum cutting depth is used. This will allow cuts with the saw blade raised to any height.
- Note:** The ZCI used should be made of sturdy material, as any deflection on the ZCI when downward pressure is applied may cause the work piece to be pulled away from the fence, resulting in a cut that is not parallel to the fence.

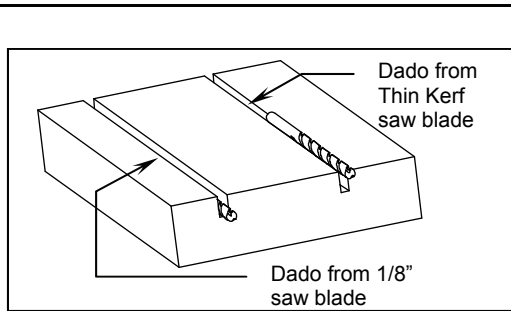

**WARNING:** MAKE SURE THAT YOU HAVE THE CORRECT MODEL OF MJ SPLITTER STEEL PRO SYSTEM FOR YOUR SAW BLADE PRIOR TO INSTALLATION. INCORRECTLY USING A THIN KERF SAW BLADE WITH A 1/8" SPLITTER WILL CAUSE BINDING AND DAMAGE THE 1/8" SPLITTER. USE OF THE WRONG MODEL MAY CAUSE INACCURATE ALIGNMENT, BINDING AND JAMMING.

If you are not sure what thickness saw blade you have mounted on your table saw, here is a simple way to find out whether you have a 1/8" or a Thin Kerf saw blade before you start the installation steps:

- 1) Raise your saw blade to 1/4" height.
  - 2) On a scrap piece of 3/4" or 1/2" thick plywood or MDF, create a single saw blade width kerf in one pass.
  - 3) Place a 1/8" drill bit into the dado.
- If the 1/8" drill bit drops to the bottom of the kerf as shown on the left side of the drawing, you have an 1/8" saw blade.
  - If the 1/8" drill bit sits on the top edges of the kerf as shown on the right side of the drawing, you have a Thin Kerf saw blade.

THE FOLLOWING STEPS ILLUSTRATE THE INSTALLATION OF BOTH THE DOUBLE MJ SPLITTER STEEL PRO AND THE MJ SPLITTER STEEL PRO/KERF KEEPER COMBINATION. FEW STEPS ARE ACTUALLY DIFFERENT BETWEEN THE TWO. THESE DIFFERENCES WILL BE MARKED WITH AN "S" FOR A DOUBLE SPLITTER INSTALLATION AND "K" FOR A SPLITTER/KERF KEEPER COMBO INSTALLATION.

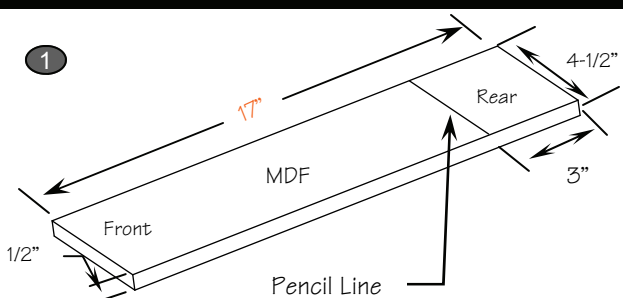

### Installation Procedure (for both 1/8" and Thin Kerf models)

These procedures are for use with a standard 10" diameter with either a 1/8" kerf or a Thin Kerf saw blade, depending on the model purchased. Please follow the exact order of steps and sequences.

#### Step 1 - Prepare two Setup Boards

Prepare two Setup Boards from 1/2" thick man-made sheet stock (preferably 1/2" MDF) - 17" L x 4-1/2" W. The front edge must be 90° to the long edges. Draw a pencil line across the width that is 3" from the rear end. Mark "A" on the top surface of one board as the Setup Board for securing the drill guide. Mark "B" on the top surface of the other board as a Test Board.

**Note:** The alignment marks on the drill guide will not work with a setup board of a thickness other than 1/2". Better grade 1/2" plywood without voids can also be used, but it must be flat and dimensionally stable. Do not use solid wood for this purpose.

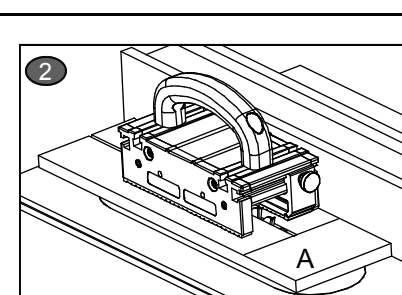

#### Step 2 - Create a Saw Kerf on both Setup Board-A and Test Board-B

- 1) Set the saw blade height at 3/4". Be sure the table saw top is clean and free from sawdust and other debris.
- 2) Secure the rip fence at 2" to the right of and parallel to the saw blade.

**IMPORTANT:** Keep the rip fence locked in this position until the installation is complete.

The saw kerf that you are going to create in the next step will be the alignment path for the Drill Guide. It is extremely important that the saw kerf is parallel to the right edge of the Setup Board. Using the GRR-Ripper® for this ripping procedure is the best way to ensure a parallel cut.

- 3) Feed Setup Board-A through the saw blade and stop at the pencil line.
- 4) Turn off the saw motor while maintaining firm pressure on the GRR-Ripper®, and wait until the saw blade comes to a complete stop. Carefully remove Setup Board-A from the saw blade.
- 5) Repeat procedures 3 & 4 above for Test Board-B.

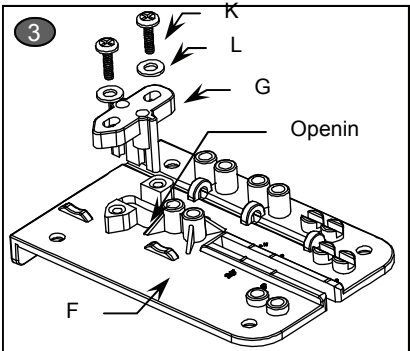

**Step 3**

- 1) Insert the Rear Drill Guide (G) through the opening on Drill Guide Base (F) with screws (K) and washers (L) as shown.
- 2) Loosely thread the screws (K) so the Rear Drill Guide (G) can slide easily from left to right.

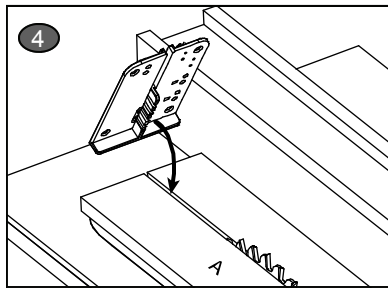

\*\*\* Disconnect the power from the table saw \*\*\*

**Step 4**

- 1) Place Setup Board-A in position as shown.
- 2) Place the Drill Guide on Setup Board-A by inserting the bottom center rib into the saw kerf. Make sure the Rear Drill Guide (G) is loosely attached so it will not affect the width of the kerf.

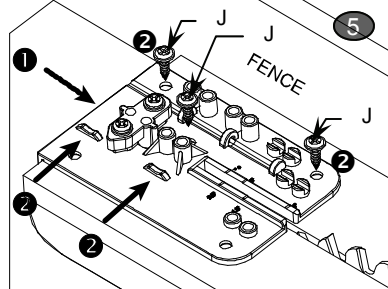

**Step 5**

- 1) Push the Drill Guide Base (F) until the cheek is in full contact with Setup Board-A.
- 2) Secure the Drill Guide Base (F) with three wood screws (J) onto the keeper piece side of Setup Board-A while applying finger pressure to the two ears in the direction of the arrows so the bottom rib of the Drill Guide is in full contact with the kerf edge of the keeper piece side of Setup Board-A.

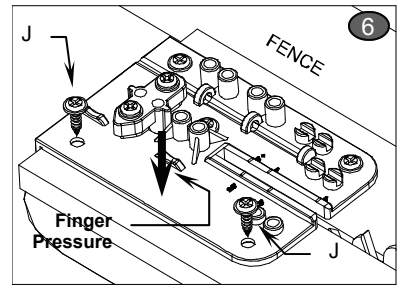

**Step 6**

Secure the Drill Guide Base (F) onto the off-cut side of Setup Board-A with two wood screws (J) while applying downward finger pressure on the off-cut side of the Drill Guide Base (F). This will help to maintain the saw kerf at its

It is recommended to establish pilot holes in the center locations for the wood screws. This will prevent the screw body pushing the drill guide out of position while tightening the screws.

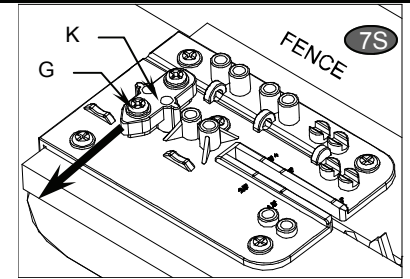

**Step 7S** - This step is for installing the Double Splitter only—continue to Step 8 after this step.

Gently slide the Rear Drill Guide (G) in the direction of the arrow (left) toward the off-cut side until the bottom ribs of the Rear Drill Guide (G) touch the kerf of the off-cut side of Setup Board-A. Secure the two machine screws (K). After drilling (Step 10), the two mounting holes for the second MJ Splitter Steel PRO will be aligned correctly to the left side of the saw kerf so it can be configured as a custom full kerf splitter system for this saw blade.

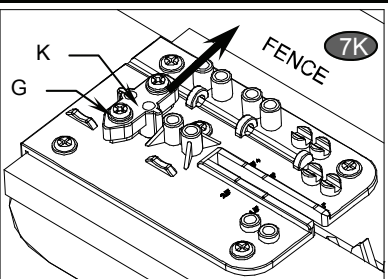

**Step 7K** - This step is for installing Splitter/Kerf Keeper Combo only—continue to Step 8 after this step.

Gently slide the Rear Drill Guide (G) in the direction of the arrow (right) toward the fence until the bottom ribs of the Rear Drill Guide (G) touch the kerf of the keeper piece side of Setup Board-A. Secure the two machine screws (K). After drilling (step 10), the two mounting holes for the Kerf Keeper will be directly in line behind the first two mounting holes for the MJ Splitter Steel PRO.

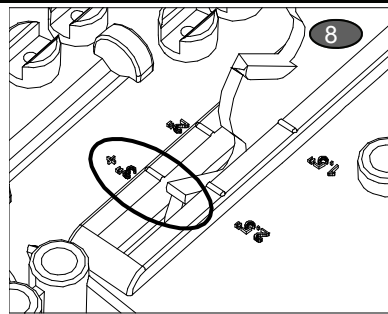

**Step 8**

- 1) Raise the 12" saw blade to its full height (approx. 4" to 4-1/4").
- 2) Rotate the saw blade by hand with a work glove or shop rag to adjust the location of Setup Board-A so that the first exposed carbide tooth at the back is flush and aligned with the 3"+ alignment mark.
- 3) **PULL the drill guide/setup board towards operator by 3/16"**

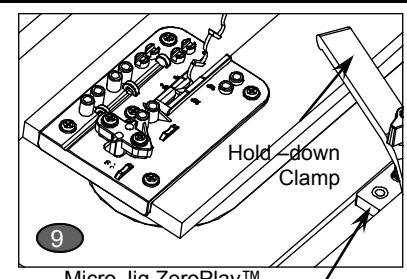

**Step 9**

1) Secure Setup Board-A in position with a clamp.  
**Note:** The illustration shows a fast and simple way of clamping Setup Board-A by using a Hold-Down Clamp and the Stop from Micro Jig's ZeroPlay™ Guide Bar System about 3"-4" away from the drill guide. You may also clamp a board bridged over Setup Board-A from the edge of your table saw top.  
 2) After clamping, be sure the carbide tip is still in line with the 3"+ alignment mark (or other alignment mark for the installation selected).

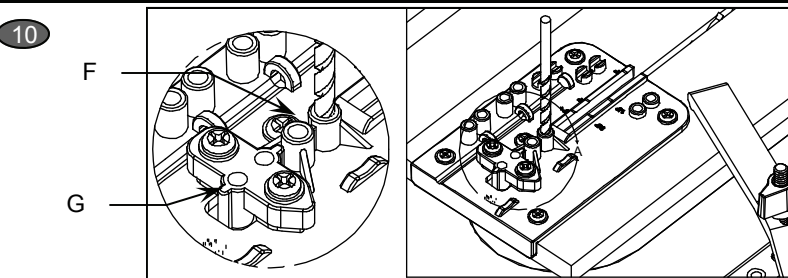

**Step 10**

- 1) Lower the saw blade to the same height of Setup Board-A to avoid drill bit contact and to keep the saw kerf in-line with the saw blade.
- 2) With a power hand drill and the provided 3/16" drill bit, drill the four (4) perpendicular mounting holes into the ZCI through the two (2) guide holes on the Drill Guide Base (F) and the two guide holes on the Rear Drill Guide (G).  
**Note:** If you are installing only one MJ Splitter Steel PRO because your ZCI is short and you do not have room for two splitters with your 10" saw blade fully raised, drill the first two holes closer to the saw blade. You can install a Double MJ Splitter Steel Pro set-up with the saw blade at a lower height (see the alignment marks on the Drill Guide Base).  
**IMPORTANT:** Drill each hole in one single quick and continuous motion. DO NOT stop-and-go or re-drill the same hole, as this will enlarge the MJ Splitter Steel PRO mounting hole and the guide hole, thus resulting in a loosely fitting MJ Splitter Steel PRO.

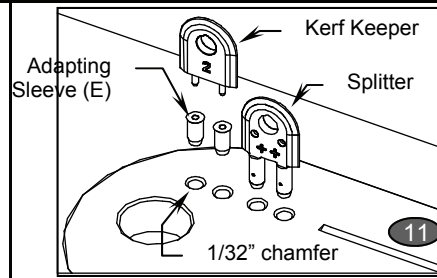

**Step 11**

Chamfer the rim of each mounting hole about 1/32" deep. The chamfer is required to allow for the Adapting Sleeve (E) to sit flush or slightly below the top surface of the ZCI. The chamfer also provides for an easier insertion of the MJ Splitter Steel PRO.  
**Note:** If you own both the 1/8" and the Thin Kerf models, DO NOT use the wrong model, as they are not interchangeable! Mark the kerf width on each ZCI accordingly.

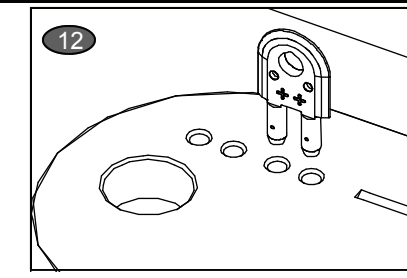

**Step 12**

Push one MJ Splitter Steel PRO in the first set of mounting holes completely down – by hand only – so that it fits tightly in the holes. If the mounting holes are too tight, you may need to ream the mounting holes lightly with the same provided drill bit. Repeat the same for the second set of mounting holes if necessary.  
 If the splitter is tight and cannot be pulled out easily by hand, insert a screw driver through the hole and pull straight up.

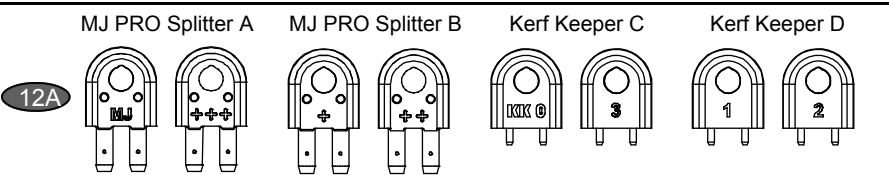

**Step 12A** - Each surface of the two MJ PRO Splitters (transparent with stainless steel core) - A & B - extends a slightly different distance from the center of the pegs. In use, each additional "+" sign indicates that surface is 0.003" closer to the fence than the surface that has one less "+" sign. This option also allows you to select a surface that protrudes slightly into the left edge of the keeper piece by thousandths of an inch, which generates slight tension - like a mini feather board - behind the saw blade. (The surface on Splitter A marked with "MJ" has a ZERO offset.)  
 Kerf Keepers (solid color) are slightly thinner than the MJ PRO Splitters but have the same amount of offsets, represented by numbers instead of "+" signs.

Replacement splitters and kerf keepers are available, please contact Micro Jig directly.

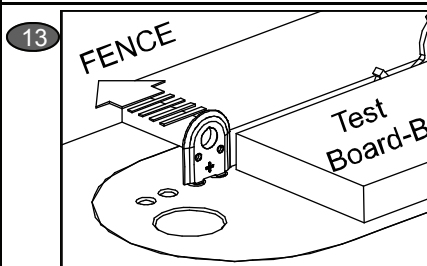

**Step 13** - In the first set of mounting holes, test both surfaces of each MJ PRO Splitter facing the rip fence with Test Board-B and select the surface that best suits your preference. When cutting material other than wood, such as aluminum or plastic, use the surface that provides no tension.

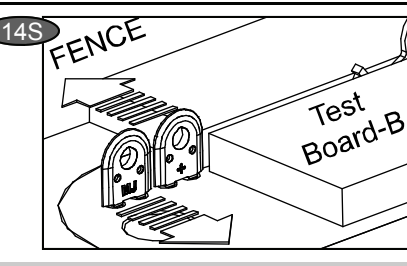

**Step 14S** - Final step for double splitter installation.  
 In the second set of mounting holes, insert another MJ PRO Splitter. This time select a surface for the off-cut piece that best suits your preference. It is recommended to have a FULL KERF effect without feather board tension on the off-cut side.

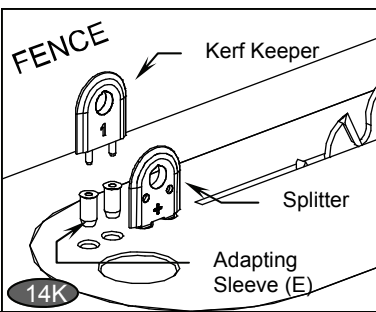

**Step 14K** - This step is for installing the Splitter/Kerf Keeper Combo only—continued from Step 13.

- 1) Insert the two Adapting Sleeves (E) securely down into the second set of mounting holes.
- 2) Insert a Kerf Keeper into the Adapting Sleeves (E). Orient a numbered surface to match the number of "+" signs on the MJ PRO Splitter, e.g., "1" to "+", "2" to "++", "3" to "+++" and "KK 0" to "MJ".

**Step 15K** - Final illustration is for a Splitter/Kerf Keeper Combo installation.

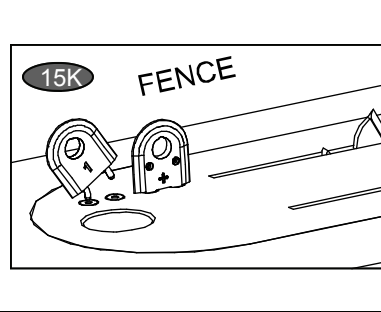

(D) When ripping a solid wood board under tension, the closing kerf will pull out the Kerf Keeper automatically. The Kerf Keeper will travel with the pinched kerf and keep the kerf open to reduce stress on the splitter and the saw blade.  
**Note:** The solid wood board referenced above is not shown in the illustration. **Important:** To ensure safe operation, turn off your table saw as soon as a closing saw kerf is observed!