

Data Sheet

Hydract double seat valves



Information

The Hydract double seat valve housing is designed in cooperation with hygienic design specialists to offer a great range of hygienic and cleanable valve houses for the process industry. The design of the valve house creates optimal conditions in terms of cleanability and flow.

It is designed to deliver high performance every time, every day!

Flow direction – the flow is bi-directional (flow can be both upstream and downstream), this also applies when using the valve for regulation.

Mixproof safety – the valve internals seal off the two pipelines to avoid any unintentional mixing of fluids. If seal leakage should occur, the leaking fluid will travel through the leakage chamber and out of the bottom of the valve thereby creating a visible leak indication.

Seals - Seals designed in collaboration with *Freudenberg Process Seals GmbH & Co.* The seal materials are EPDM for static, axial and the lower seat seal. Shaft seals are a two-part seal, the material in contact with the shaft is a filled PTFE and the energising ring is EPDM.

Seat Calibration – The O-ring compression on the upper seat can be adjusted by connecting the actuator to a tablet using the Hydract app.

Flow conditions – the conical shape of the lower seat allows for optimal flow when opening, closing, or using the valve for regulation. The reduced pressure drops inherent with this design, is used to gain more control over the same stroke, thus giving more stability, especially when used in regulation operation. The shape of the flow controlling surface can be engineered to meet the need of the process, i.e. quick opening, equal percentage, and other types of valve control.

The valve houses are clamped together with the actuator using standard tri-clamps to ensure fast and easy assembly of the total valve system.

The valve sizes and dimensions are shown in below table.

For more and customized sizes please contact Hydract.

Features and benefits

- Hygienic design
- Easy to clean
- Bi-directional flow
- All valves can be regulating valves

Data Sheet

Hydract double seat valves



Dimensions

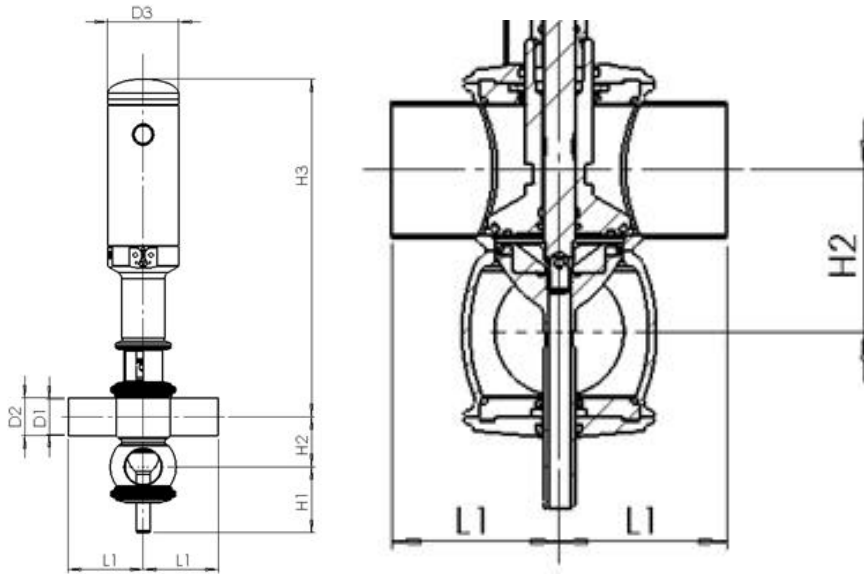

Double seat small valve type

DN/ISO	ØD1	ØD2	ØD3	L1	H1	H2	H3
	mm	mm	mm	mm	mm	mm	mm
40	38	41	99	90	87	58	467
50	50	53	99	90	93	70	473
1½"	38,1	41,4	99	90	87	58,1	467
2"	50,4	53,7	99	90	93	70,4	473

Double seat medium type

DN/ISO	ØD1	ØD2	ØD3	L1	H1	H2	H3
	mm	mm	mm	mm	mm	mm	mm
65	66	70	99	105	115	86	561
80	81	85	99	105	122	101	568
100	100	104	99	105	132	120	578
2½"	63,5	66,8	99	105	114	83,5	560
3"	76,2	79,5	99	105	120	96,2	566
4"	101,6	105,8	99	105	133	121,6	579

Data Sheet

Hydract double seat valves



Technical data

Pressure

Product Pressure	PN 145 psi (10 bar) / vacuum -13,8 psi (0,95 bar)
Housing	PN 360 psi (25 bar)
Pressure resistance	PN 650 psi (45 bar)

Material

With product contact	AISI 316 L / EN 1.4404
Without product contact	AISI 304 / EN 1.4301
Seal	EPDM and Filled PTFE Other materials available on request

Surface

With product contact	Ra ≤ 0.8 μm
Without product contact	Ra ≤ 1.6 μm

Hydract Process Valve Operation when in Passive State

The Hydract range of process valves do not have a spring incorporated inside the actuator and must therefore operate in a different way when compared with conventional pneumatic process valves.

When a Hydract process valve is first installed, a seat calibration must be performed for the valve to determine where the seat positions are. The valve will save these positions in non-volatile memory. This will only be overwritten when a new seat calibration is performed.

When the process valve is in a passive state the actuators hydraulic pilot valve/s are in the locked position, i.e. all ports (Pressure, Tank, A and B) are closed and sealed off by hydraulic seals. This stops fluid from entering or exiting the main piston chambers, locking them in position.

Both process valve piston positions (upper and lower) are measured continuously with an accuracy of ±0.05mm. Should there be movement of the process pistons outside of the tolerance set for the seat positions (±0.1mm for upper seat and ±0.3mm for lower seat), the valve will move back to the originally measured and saved position while in the passive state.

The actuator piston movement could be due to internal leakage inside the actuators hydraulic pilot valves or actuator piston seals. When the actuator performs this seat adjustment a counter is incremented internally in the actuator's memory statistics. This counter is then used to determine the health of the actuator and will present a warning to the user through the communication BUS or tablet.